

# ***STRAINERS***

***“Y” FORGED***

***“Y” CAST***

***TEMPORARY***

***TEE***

***SIMPLEX***

***GO BACK***



# “ Y “ FORGED

*F 800 A105*

*F 800 F316*

*F 1500 A105*

*F 1500 F316*

**GO BACK**

## STRAINERS

Designed to ANSI B16.34 the strainer bodies are produced with a superior wallthickness for corrosion allowance.

Standard strainers are equipped with screens for the average service of most mediums ( steam, gas, air, oil, chemicals , ect. ).

The large screen open area ensures an efficient filtering action with a low pressure drop.

Filtering area to inlet area ratio is larger than 3 to 1.

Screens area manufactured with perforated plate in the materials and with the perforation specified in the relevant tables .

Screens with different perforation ( or wire mesh ) and materials may be manufactured on request.



## INSTALLATION

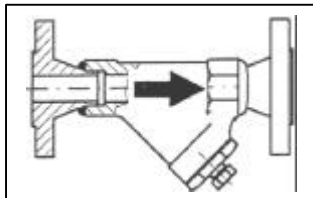

**1 CORRECT**

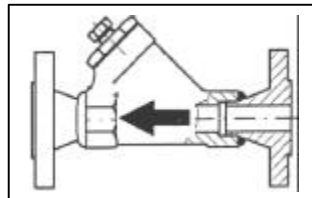

**2 INCORRECT**

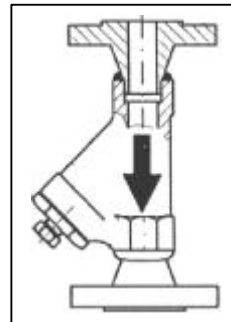

**3 CORRECT**

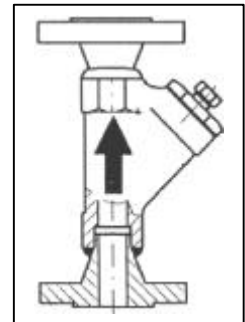

**4 INCORRECT**

- All strainers should be mounted as close as possible to the valve or machinery which they are being installed to protect. It is important to ensure that the strainer installed with the flow following the same direction as the flow direction arrow cast onto the strainer body.
- For mounting in horizontal or inclined pipelines, ensure that the screen housing is always mounted below the pipeline.
- "Y" – strainers should never be installed in vertical pipelines in the upward flow condition. ( see above )

### SIZES

3/8" – 1/2" – 3/4" – 1" – 1 1/2" – 2"

### CONNECTIONS

Screwed	ANSI B1.20.1 (NPT) / BS21 (BSP)
Buttweld	ANSI B16.25
Socket Welding	ANSI B16.11
Flanged	ANSI / UNI / DIN

### LIMITING CONDITIONS ( according to ISO 6552 )

According to the body rating ( ANSI B16.34 )  
F800 –ANSI 800  
OTHER RATINGS ON REQUEST

## FORGED STEEL "Y" TYPE STRAINER DOUGLAS F800 A105

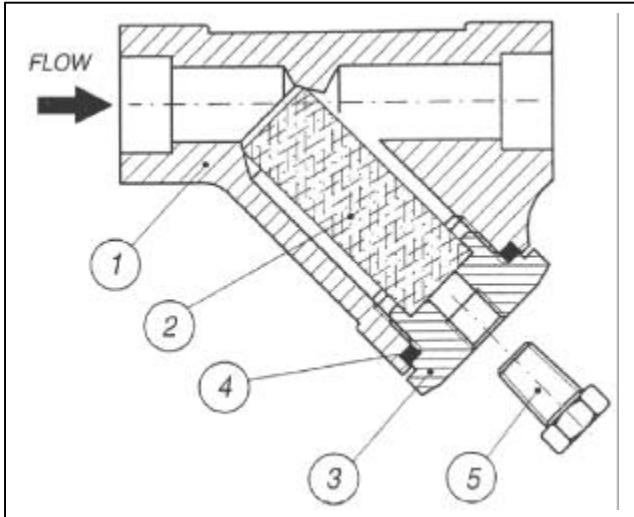

POS.	DESCRIPTION	MATERIALS	SPARES
1	Body	ASTM A105	
2	Screen	S.S.	
3	Plug	ASTM A105	
4	Gasket	316 / GRAPHITE	
5	Drain plug	ASTM A105	
6	Studs	ASTM A193 B7	
6	Nuts	ASTM A194 2H	
7	Flange	ASTM A105	

POS.6 (BOLTED COVER) : F800 2" ONLY  
OTHER MATERIALS ON REQUEST

Size (inches)	DRAIN PLUG	S	H	H1	C	Weight (Kg)	Flanged							
							UNI-DIN PN16-25-40 SF Kg		150# SF Kg		300# SF Kg		600# SF Kg	
3/8"	1/4"	90	60	85	41	1	-	-	-	-	-	-	-	-
1/2"	1/4"	90	60	85	41	1	150	2.6	165	2.3	165	2.8	165	3.2
3/4"	1/4"	110	75	100	46	1.2	170	4	191	3.2	191	4.3	191	4.7
1"	1/4"	130	93	140	56	2	200	4.4	216	4.2	216	5.3	216	5.8
1 1/2"	1/4"	180	144	200	85	6	240	11	241	9.7	241	15	241	12.9
2"	1/2"	185	140	200	100	7	230	13	292	12	292	15	292	16.3

STANDARD PERFORATIONS 0.8mm  
SPECIAL PERFORATIONS ON REQUEST  
Dimension : S, H, H1, C, SF are in millimeters ( mm)

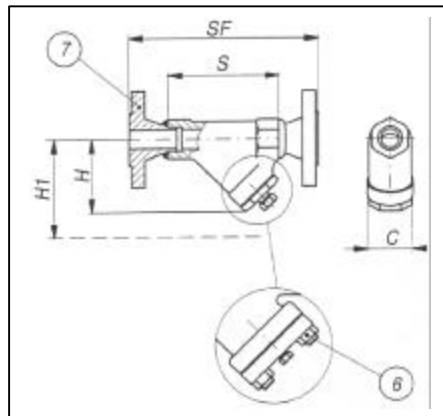

### HOW TO SERVICE

Strainer maintenance should be made at least once year, or whenever the pressure drop is found to be in excess of the normal figures. A quick clean-up system, to made approximately once a month, is to blow-off small impurities trough the drain-plug (5). It is recommended to install a drain valve by a nipple to the drain hole to speed-up this operation. For a complete maintenance follow the points herebelow: -1- Be sure that the main line has been shut-off. -2- Remove cover (3) and gasket (4). -3- Withdraw screen (2) and carefully inspect it for damages. If any hole in the screen is found obstructed, clean it with compressed air and / or any suitable tool. If the screen is broken in any part or out of shape, replace it with a new spare one. **Never reinstall a broken or distorted screen.** -4- Carefully clean the inside of the strainer body. -5- Fit a new gasket (4). -6- Install the new screen or the cleaned one (2). Be sure to center the screen in the upper seat. -7- Put in place cover (3). Be sure that drain plug (5) is closed. -8- Slowly give pressure to the line, checking for leakages. -9- Write on the strainer body the date of this maintenance operation.

**How to order:** i.e. F800 A105 /304 F 0.8 1" NPT

**DOUGLAS ITALIA S.p.A** Località Pradaglie – 29013 CARPANETO PIACENTINO ( PC )

OFFICIAL WEB SITE: [www.douglas-italia.com](http://www.douglas-italia.com)

## STRAINERS

Designed to ANSI B16.34 the strainer bodies are produced with a superior wallthickness for corrosion allowance.

Standard strainers are equipped with screens for the average service of most mediums ( steam, gas, air, oil, chemicals , ect. ).

The large screen open area ensures an efficient filtering action with a low pressure drop.

Filtering area to inlet area ratio is larger than 3 to 1 . Screens area manufactured with perforated plate in the materials and with the perforation specified in the relevant tables .

Screens with different peforation ( or wire mesh ) and materials may be manufactured on request.



## INSTALLATION

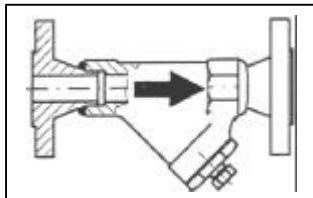

**1 CORRECT**

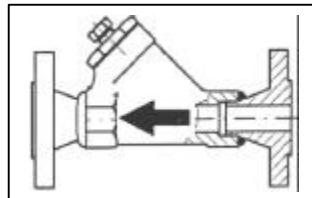

**2 INCORRECT**

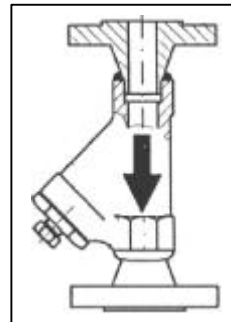

**3 CORRECT**

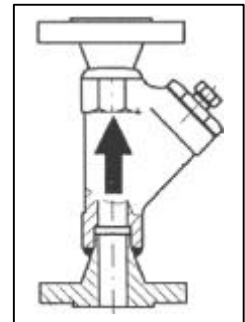

**4 INCORRECT**

- All strainers should be mounted as close as possible to the valve or machinery which they are being installed to protect. It is important to ensure that the strainer installed with the flow following the same direction as the flow direction arrow cast onto the strainer body.
- For mounting in horizontal or inclined pipelines, ensure that the screen housing is always mounted below the pipeline.
- " Y " – strainers should never be installed in vertical pipelines in the upward flow condition. ( see above )

### SIZES

3/8" – 1/2" – 3/4" – 1" – 1 1/2" – 2"

### CONNECTIONS

Screwed	ANSI B1.20.1 (NPT) / BS21 (BSP)
Buttweld	ANSI B16.25
Socket Welding	ANSI B16.11
Flanged	ANSI / UNI / DIN

### LIMITING CONDITIONS ( according to ISO 6552 )

According to the body rating ( ANSI B16.34 )  
F800 –ANSI 800  
OTHER RATINGS ON REQUEST



## FORGED STEEL " Y " TYPE STRAINER DOUGLAS F800 F316

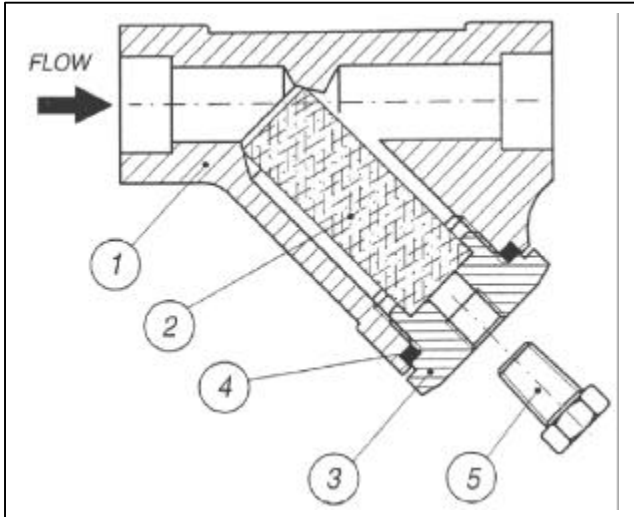

POS.	DESCRIPTION	MATERIALS	SPARES
1	Body	ASTM A182 F316	
2	Screen	S.S.	
3	Plug	AISI 316	
4	Gasket	316 / GRAPHITE	
5	Drain plug	ASTM A182 F316	
6	Studs	ASTM A193 B8	
6	Nuts	ASTM A194 2Gr.8	
7	Flange	ASTM A182 F316	

POS.6 (BOLTED COVER) : F800 2" ONLY  
OTHER MATERIALS ON REQUEST

Size (inches)	DRAIN PLUG	S	H	H1	C	Weight (Kg)	Flanged							
							UNI-DIN PN16-25-40		150#		300#		600#	
							SF	Kg	SF	Kg	SF	Kg	SF	Kg
3/8"	1/4"	90	60	85	41	1	-	-	-	-	-	-	-	-
1/2"	1/4"	90	60	85	41	1	150	2.6	165	2.3	165	2.8	165	3.2
3/4"	1/4"	110	75	100	46	1.2	170	4	191	3.2	191	4.3	191	4.7
1"	1/4"	130	93	140	56	2	200	4.4	216	4.2	216	5.3	216	5.8
1 1/2"	1/4"	180	144	200	85	6	240	11	241	9.7	241	15	241	12.9
2"	1/2"	185	140	200	100	7	230	13	292	12	292	15	292	16.3

STANDARD PERFORATIONS 0.8mm  
SPECIAL PERFORATIONS ON REQUEST  
Dimension : S, H, H1, C, SF are in millimeters ( mm)

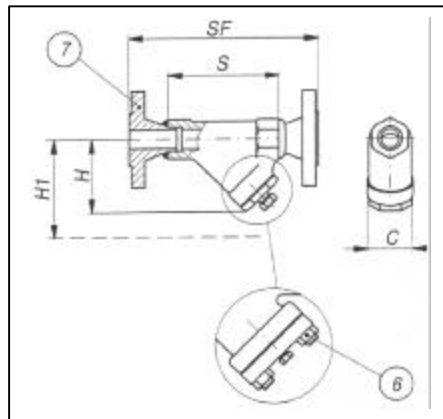

### HOW TO SERVICE

Strainer maintenance should be made at least once year, or whenever the pressure drop is found to be in excess of the normal figures. A quick clean-up system, to made approximately once a month, is to blow-off small impurities trough the drain-plug (5). It is recommended to install a drain valve by a nipple to the drain hole to speed-up this operation. For a complete maintenance follow the points herebelow: -1- Be sure that the main line has been shut-off. -2- Remove cover (3) and gasket (4). -3- Withdraw screen (2) and carefully inspect it for damages. If any hole in the screen is found obstructed, clean it with compressed air and / or any suitable tool. If the screen is broken in any part or out of shape, replace it with a new spare one. **Never reinstall a broken or distorted screen.** -4- Carefully clean the inside of the strainer body. -5- Fit a new gasket (4). -6- Install the new screen or the cleaned one (2). Be sure to center the screen in the upper seat. -7- Put in place cover (3). Be sure that drain plug (5) is closed. -8- Slowly give pressure to the line, checking for leakages. -9- Write on the strainer body the date of this maintenance operation.

**How to order: i.e.** F800 F316 / 316 F 0.8 1" NPT

**DOUGLAS ITALIA S.p.A** Località Pradaglie – 29013 CARPANETO PIACENTINO ( PC )

OFFICIAL WEB SITE: [www.douglas-italia.com](http://www.douglas-italia.com)

## STRAINERS

Designed to ANSI B16.34 the strainer bodies are produced with a superior wallthickness for corrosion allowance.

Standard strainers are equipped with screens for the average service of most mediums ( steam, gas, air, oil, chemicals , ect. ).

The large screen open area ensures an efficient filtering action with a low pressure drop.

Filtering area to inlet area ratio is larger than 3 to 1 . Screens area manufactured with perforated plate in the materials and with the perforation specified in the relevant tables .

Screens with different perforation ( or wire mesh ) and materials may be manufactured on request.



## INSTALLATION

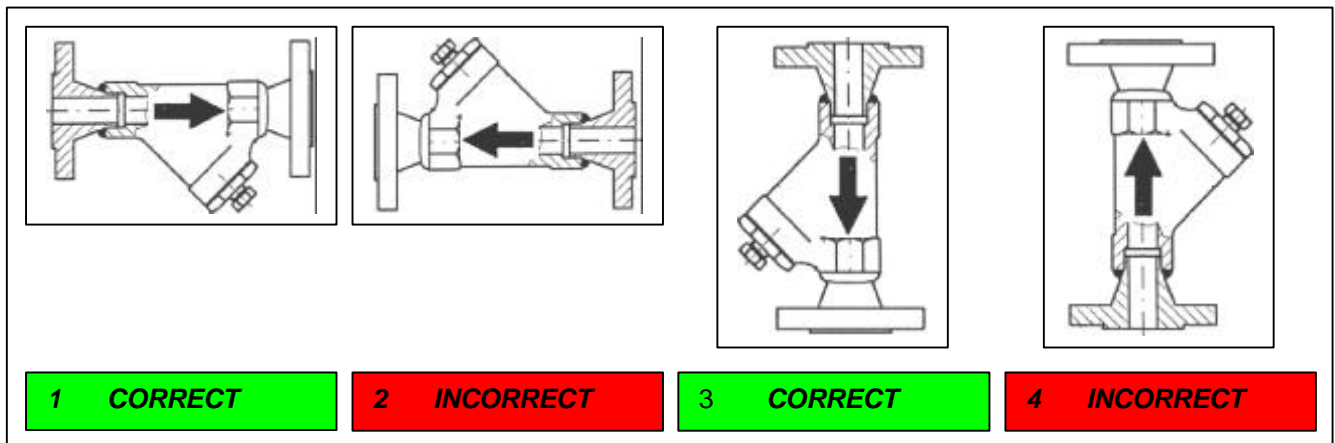

- All strainers should be mounted as close as possible to the valve or machinery which they are being installed to protect. It is important to ensure that the strainer installed with the flow following the same direction as the flow direction arrow cast onto the strainer body.
- For mounting in horizontal or inclined pipelines, ensure that the screen housing is always mounted below the pipeline.
- " Y " – strainers should never be installed in vertical pipelines in the upward flow condition. ( see above )

### SIZES

3/8" – 1/2" – 3/4" – 1" – 1 1/2" – 2"

### CONNECTIONS

Screwed	ANSI B1.20.1 (NPT) / BS21 (BSP)
Buttweld	ANSI B16.25
Socket Welding	ANSI B16.11
Flanged	ANSI / UNI / DIN

### LIMITING CONDITIONS ( according to ISO 6552 )

According to the body rating ( ANSI B16.34 )  
F1500 –ANSI 1500  
OTHER RATINGS ON REQUEST

## FORGED STEEL " Y " TYPE STRAINER DOUGLAS F1500 A105

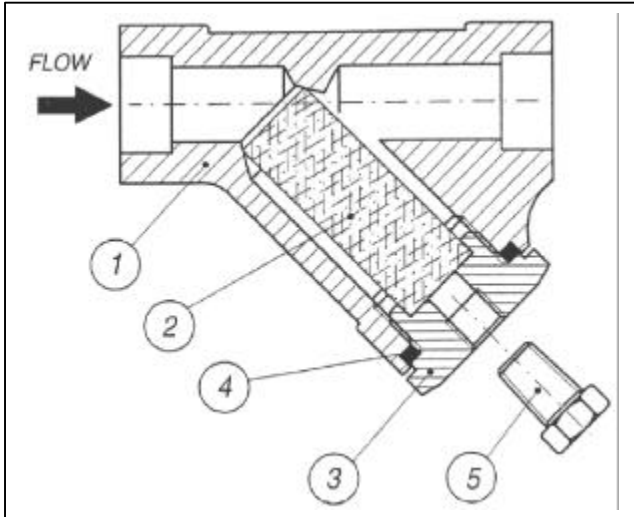

POS.	DESCRIPTION	MATERIALS	SPARES
1	Body	ASTM A105	
2	Screen	S.S.	
3	Plug	ASTM A105	
4	Gasket	316 / GRAPHITE	
5	Drain plug	ASTM A105	
6	Studs	ASTM A193 B7	
6	Nuts	ASTM A194 2H	
7	Flange	ASTM A105	

POS.6 (BOLTED COVER) : F1500 1½" ONLY  
OTHER MATERIALS ON REQUEST

Flanged								
Size (inches)	DRAIN PLUG	S	H	H1	C	Weight (Kg)	1500#	
							SF	Kg
½"	¼"	110	75	100	46	1.4	216	5.5
¾"	¼"	130	93	140	56	2.2	229	7
1"	¼"	180	144	200	85	6.2	254	13
1½"	½"	185	140	200	100	7.5	305	19

STANDARD PERFORATIONS 0.8mm  
SPECIAL PERFORATIONS ON REQUEST  
Dimension : S, H, H1, C, SF are in millimeters ( mm)

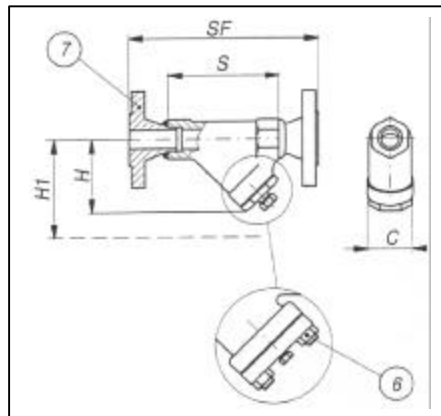

### HOW TO SERVICE

Strainer maintenance should be made at least once year, or whenever the pressure drop is found to be in excess of the normal figures. A quick clean-up system, to made approximately once a month, is to blow-off small impurities trough the drain-plug (5). It is recommended to install a drain valve by a nipple to the drain hole to speed-up this operation. For a complete maintenance follow the points herebelow: -1- Be sure that the main line has been shut-off. -2- Remove cover (3) and gasket (4). -3- Withdraw screen (2) and carefully inspect it for damages. If any hole in the screen is found obstructed, clean it with compressed air and / or any suitable tool. If the screen is broken in any part or out of shape, replace it with a new spare one. **Never reinstall a broken or distorted screen.** -4- Carefully clean the inside of the strainer body. -5- Fit a new gasket (4). -6- Install the new screen or the cleaned one (2). Be sure to center the screen in the upper seat. -7- Put in place cover (3). Be sure that drain plug (5) is closed. -8- Slowly give pressure to the line, checking for leakages. -9- Write on the strainer body the date of this maintenance operation.

**How to order: i.e.** F1500 A105 /304 F 0.8 1" NPT

**DOUGLAS ITALIA S.p.A** Località Pradaglie – 29013 CARPANETO PIACENTINO ( PC )

OFFICIAL WEB SITE: [www.douglas-italia.com](http://www.douglas-italia.com)



## STRAINERS

Designed to ANSI B16.34 the strainer bodies are produced with a superior wallthickness for corrosion allowance.

Standard strainers are equipped with screens for the average service of most mediums ( steam, gas, air, oil, chemicals , ect. ).

The large screen open area ensures an efficient filtering action with a low pressure drop.

Filtering area to inlet area ratio is larger than 3 to 1 . Screens area manufactured with perforated plate in the materials and with the perforation specified in the relevant tables .

Screens with different perforation ( or wire mesh ) and materials may be manufactured on request.



## INSTALLATION

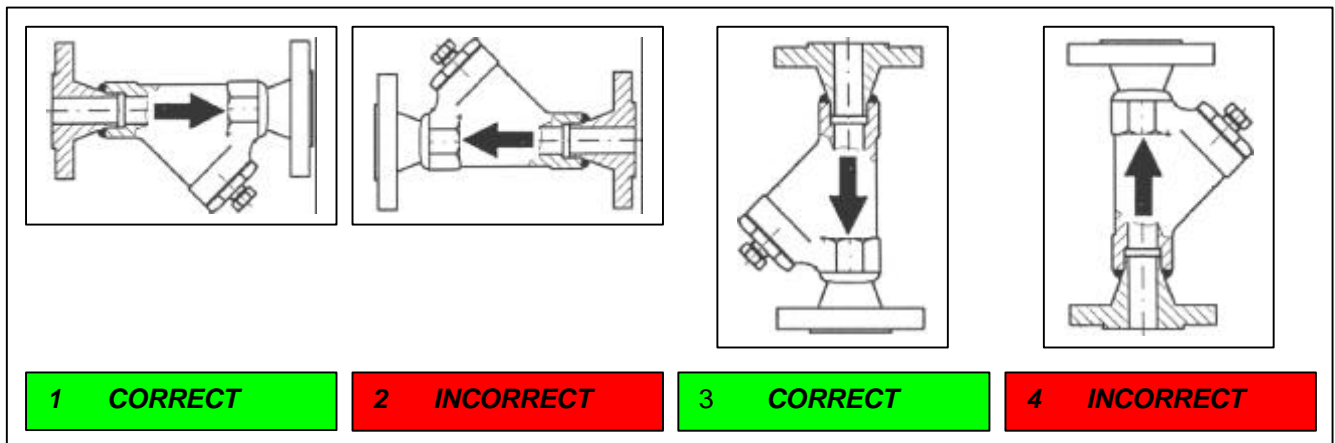

- All strainers should be mounted as close as possible to the valve or machinery which they are being installed to protect. It is important to ensure that the strainer installed with the flow following the same direction as the flow direction arrow cast onto the strainer body.
- For mounting in horizontal or inclined pipelines, ensure that the screen housing is always mounted below the pipeline.
- " Y " – strainers should never be installed in vertical pipelines in the upward flow condition. ( see above )

### SIZES

3/8" – 1/2" – 3/4" – 1" – 1 1/2" – 2"

### CONNECTIONS

Screwed	ANSI B1.20.1 (NPT) / BS21 (BSP)
Buttweld	ANSI B16.25
Socket Welding	ANSI B16.11
Flanged	ANSI / UNI / DIN

### LIMITING CONDITIONS ( according to ISO 6552 )

According to the body rating ( ANSI B16.34 )  
F1500 –ANSI 1500  
OTHER RATINGS ON REQUEST

## FORGED STEEL " Y " TYPE STRAINER DOUGLAS F1500 F316

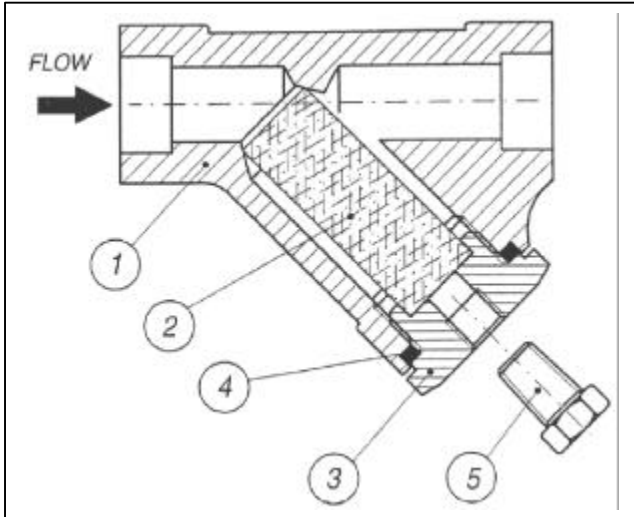

POS.	DESCRIPTION	MATERIALS	SPARES
1	Body	ASTM A182 F316	
2	Screen	S.S.	
3	Plug	AISI 316	
4	Gasket	316 / GRAPHITE	
5	Drain plug	ASTM A182 F316	
6	Studs	ASTM A193 B8	
6	Nuts	ASTM A194 2Gr.8	
7	Flange	ASTM A182 F316	

POS.6 (BOLTED COVER) : F1500 1½" ONLY  
OTHER MATERIALS ON REQUEST

Flanged								
Size (inches)	DRAIN PLUG	S	H	H1	C	Weight (Kg)	1500#	
							SF	Kg
½"	¼"	110	75	100	46	1.4	216	5.5
¾"	¼"	130	93	140	56	2.2	229	7
1"	¼"	180	144	200	85	6.2	254	13
1½"	½"	185	140	200	100	7.5	305	19

STANDARD PERFORATIONS 0.8mm  
SPECIAL PERFORATIONS ON REQUEST  
Dimension : S, H, H1, C, SF are in millimeters ( mm)

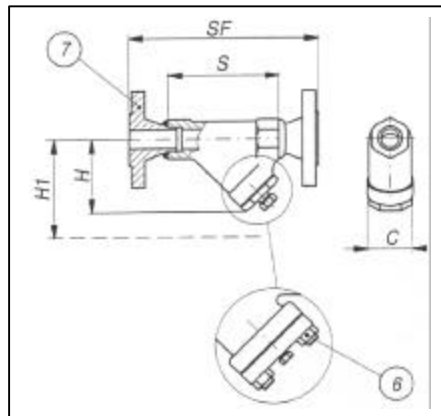

### HOW TO SERVICE

Strainer maintenance should be made at least once year, or whenever the pressure drop is found to be in excess of the normal figures. A quick clean-up system, to made approximately once a month, is to blow-off small impurities trough the drain-plug (5). It is recommended to install a drain valve by a nipple to the drain hole to speed-up this operation. For a complete maintenance follow the points herebelow: -1- Be sure that the main line has been shut-off. -2- Remove cover (3) and gasket (4). -3- Withdraw screen (2) and carefully inspect it for damages. If any hole in the screen is found obstructed, clean it with compressed air and / or any suitable tool. If the screen is broken in any part or out of shape, replace it with a new spare one. **Never reinstall a broken or distorted screen.** -4- Carefully clean the inside of the strainer body. -5- Fit a new gasket (4). -6- Install the new screen or the cleaned one (2). Be sure to center the screen in the upper seat. -7- Put in place cover (3). Be sure that drain plug (5) is closed. -8- Slowly give pressure to the line, checking for leakages. -9- Write on the strainer body the date of this maintenance operation.

**How to order: i.e.** F1500 F316 / 316 F 0.8 1" NPT

**DOUGLAS ITALIA S.p.A** Località Pradaglie – 29013 CARPANETO PIACENTINO ( PC )

OFFICIAL WEB SITE: [www.douglas-italia.com](http://www.douglas-italia.com)

## STRAINERS

Designed to ANSI B16.34 the strainer bodies are produced with a superior wall thickness for corrosion allowance.

Standard strainers are equipped with screens for the average service of most mediums ( steam, gas, air, oil, chemicals , ect. ).

The large screen open area ensures an efficient filtering action with a low pressure drop.

Filtering area to inlet area ratio is larger than 3 to 1 . Screens area manufactured with perforated plate in the materials and with the perforation specified in the relevant tables .

Screens with different perforation ( or wire mesh ) and materials may be manufactured on request.

## INSTALLATION

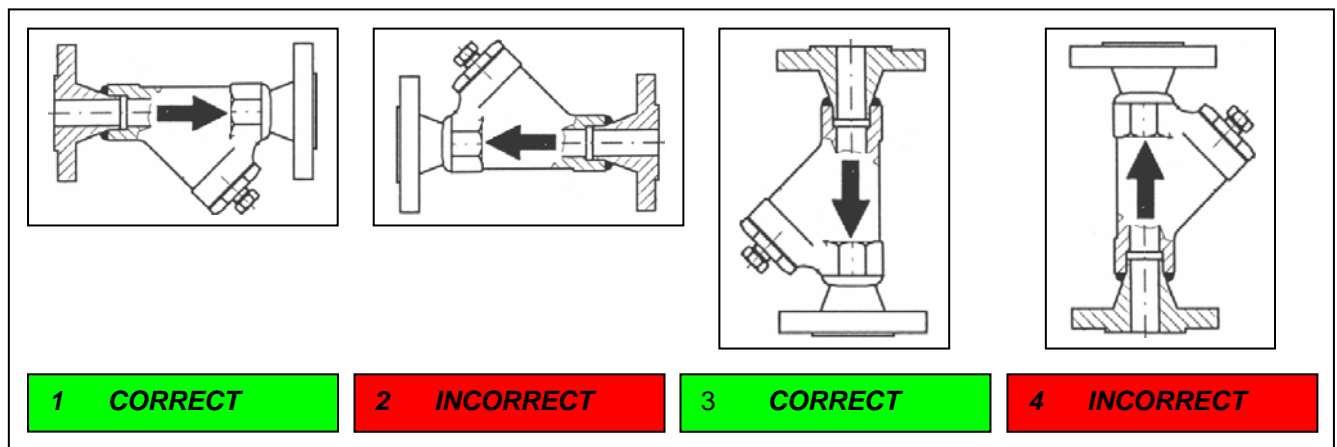

- All strainers should be mounted as close as possible to the valve or machinery which they are being installed to protect. It is important to ensure that the strainer installed with the flow following the same direction as the flow direction arrow cast onto the strainer body.
- For mounting in horizontal or inclined pipelines, ensure that the screen housing is always mounted below the pipeline.
- " Y " – strainers should never be installed in vertical pipelines in the upward flow condition. ( see above )

### SIZES

½" – ¾" - 1" – 1½" – 2"

### CONNECTIONS

Buttweld	ANSI B16.25
Socket Welding	ANSI B16.11

### LIMITING CONDITIONS ( according to ISO 6552 )

According to the body rating ( ANSI B16.34 )  
F2500-ANSI 2500  
OTHER RATINGS ON REQUEST

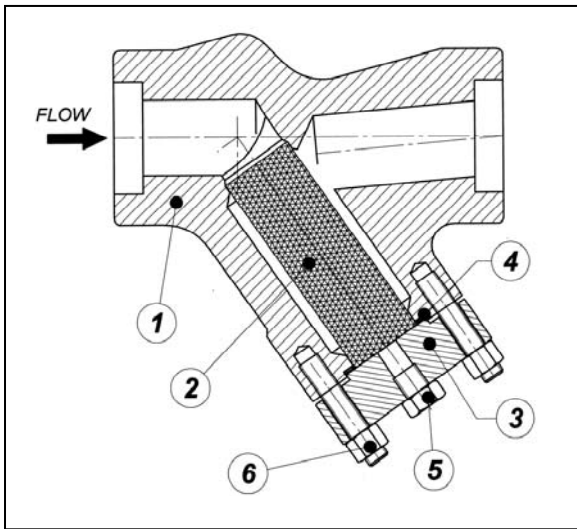

POS.	DESCRIPTION	MATERIALS	SPARES
1	Body	AS PER M.R.	
2	Screen Perforation holes $\varnothing$ 0,8 mm		
3	Cover		
4	Gasket		
5	Drain plug		
6	Studs		
6	Nuts		

Size (inches)	DRAIN PLUG	S	H	H1
1/2" 2500#	1/4" NPT	190	160	220
3/4" 2500#	1/4" NPT	190	160	220
1" 2500#	1/4" NPT	190	160	220
1.1/2" 2500#	1/4" NPT	190	170	230
2" 2500#	1/2" NPT	213	190	260

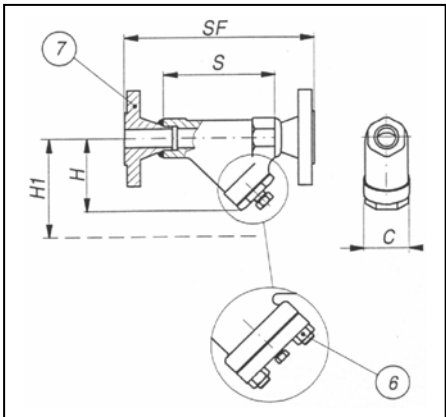

**HOW TO SERVICE**

Strainer maintenance should be made at least once year, or whenever the pressure drop is found to be in excess of the normal figures. A quick clean-up system, to made approximately once a month, is to blow-off small impurities trough the drain-plug (5). It is recommended to install a drain valve by a nipple to the drain hole to speed-up this operation. For a complete maintenance follow the points herebelow: -1- Be sure that the main line has been shut-off. -2- Remove cover (3) and gasket (4). -3- Withdraw screen (2) and carefully inspect it for damages. If any hole in the screen is found abstracted, clean it with compressed air and / or any suitable tool. If the screen is broken in any part or out of shape, replace it with a new spare one. **Never reinstall a broken or distorted screen.** -4- Carefully clean the inside of the strainer body. -5- Fit a new gasket (4). -6- Install the new screen or the cleaned one (2). Be sure to center the screen in the upper seat. -7- Put in place cover (3). Be sure that drain plug (5) is closed. -8- Slowly give pressure to the line, checking for leakages. -9- Write on the strainer body the date of this maintenance operation.

MODEL & CONNECTIONS			CLIENT REF.	
MODEL	SIZE	CONNECTIONS	ITEM No.:	TAG.No.:
DOUGLAS REF				
CLIENT				
CLIENT P.O. No.				
CLIENT M.R. No.				

# “ Y “ CAST

**C 150 WCB**

**C 150 CF8M**

**C 300 WCB**

**C 300 CF8M**

**C 600 WCB**

**C 600 CF8M**

**C 900 WCB**

**C 900 CF8M**

**C 900 PS WCB**

**C 900 PS CF8M**

**C 1500 WCB**

**C 1500 CF8M**

**C 1500 PS WCB**

**C 1500 PS CF8M**

**GO BACK**



## STRAINERS

Designed to ANSI B16.34 the strainer bodies are produced with a superior wall thickness for corrosion allowance.

Standard strainers are equipped with screens for the average service of most mediums ( steam, gas, air, oil, chemicals , ect. ).

The large screen open area ensures an efficient filtering action with a low pressure drop.

Filtering area to inlet area ratio is larger than 3 to 1 . Screens area manufactured with perforated plate in the materials and with the perforation specified in the relevant tables .

Screens with different perforation ( or wire mesh ) and materials may be manufactured on request.



## INSTALLATION

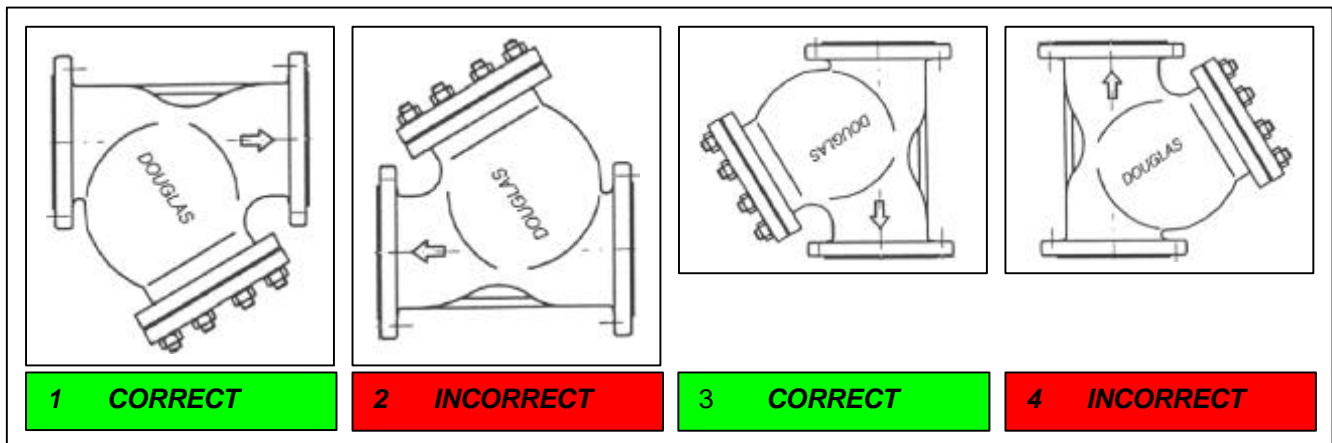

- All strainers should be mounted as close as possible to the valve or machinery which they are being installed to protect. It is important to ensure that the strainer installed with the flow following the same direction as the flow direction arrow cast onto the strainer body.
- For mounting in horizontal or inclined pipelines, ensure that the screen housing is always mounted below the pipeline.
- " Y " – strainers should never be installed in vertical pipelines in the upward flow condition. ( see above )

### SIZES

2"-3"-4"-6"-8"-10"-12"-14"-16"-18"-20"-24"

### CONNECTIONS

Buttweld	ANSI B16.25
Flanged	ANSI B 16.5

### LIMITING CONDITIONS ( according to ISO 6552 )

According to the body rating ( ANSI B16.34 )  
C150 – ANSI 150  
OTHER RATINGS ON REQUEST

## CAST STEEL " Y " TYPE STRAINERS DOUGLAS C150 WCB

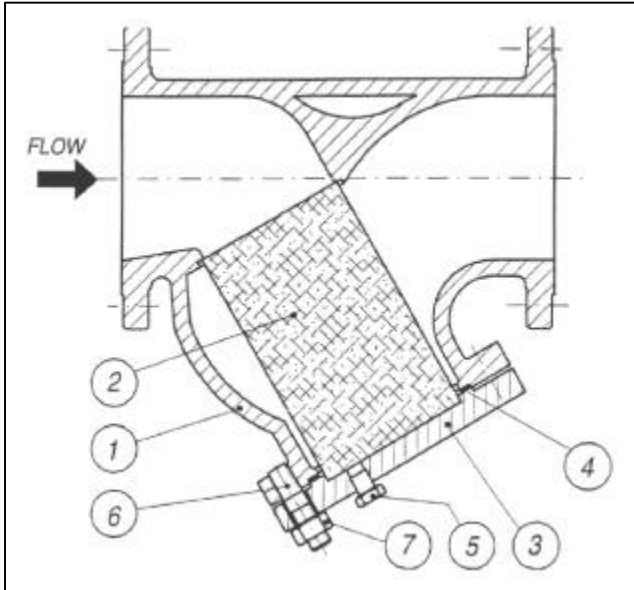

POS.	DESCRIPTION	MATERIALS	SPARES
1	Body	ASTM A216 WCB	
2	Screen	S.S. 304	X
3	Cover	ASTM A105	
4	Gasket	316 / GRAPHITE	X
5	Drain plug	ASTM A105	
6	Studs	ASTM A193 B7	
7	Nuts	ASTM A194 2H	

OTHER MATERIALS ON REQUEST

Size (inches)	2"	3"	4"	6"	8"	10"	12"	14"	16"	18"	20"	24"
SRF	203	241	292	406	495	622	699	788	914	978	978	1295
S	203	241	292	406	495	622	699	788	914	978	978	1295
H	140	210	270	360	460	570	700	770	870	975	1095	1300
H1	190	260	340	400	580	660	800	1200	1400	1530	1750	2040
Kg	14	26	40	68	140	190	270	350	640	700	895	1370

STANDARD PERFORATIONS 1.5 mm  
SPECIAL PERFORATIONS ON REQUEST . DRAIN PLUG SIZE ¾"  
Dimension : SRF , S , H , H1 are in millimeters ( mm)

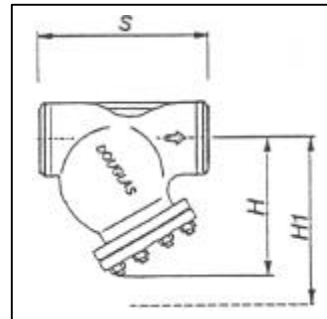
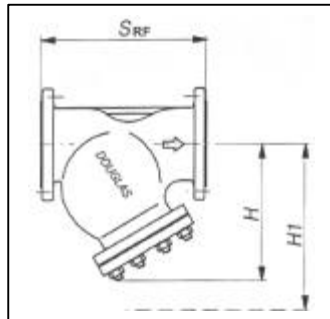

### HOW TO SERVICE

Strainer maintenance should be made at least once year, or whenever the pressure drop is found to be in excess of the normal figures. A quick clean-up system, to made approximately once a month, is to blow-off small impurities through the drain-plug (5). It is recommended to install a drain valve by a nipple to the drain hole to speed-up this operation. For a complete maintenance follow the points herebelow: **-1-** Be sure that the main line has been shut-off. **-2-** Untighten cover stud bolts (6) and nuts (7) and remove cover (3) and gasket (4). **-3-** Withdraw screen (2) and carefully inspect it for damages. If any hole in the screen is found abstracted, clean it with compressed air and / or any suitable tool. If the screen is broken in any part or out of shape, replace it with a new spare one. **Never reinstall a broken or distorted screen.** **-4-** Carefully clean the inside of the strainer body. **-5-** Fit a new gasket (4). **-6-** Install the new screen or the cleaned one (2). Be sure to center the screen in the upper seat. **-7-** Put in place cover (3). Be sure that drain plug (5) is closed. **-8-** Slowly give pressure to the line, checking for leakages. **-9-** Write on the strainer body the date of this maintenance operation.

**How to order: i.e.** C150 WCB / 304 F 1.5 2" 150 RF

**DOUGLAS ITALIA S.p.A** Località Pradaglie – 29013 CARPANETO PIACENTINO ( PC )

OFFICIAL WEB SITE: [www.douglas-italia.com](http://www.douglas-italia.com)

## STRAINERS

Designed to ANSI B16.34 the strainer bodies are produced with a superior wall thickness for corrosion allowance.

Standard strainers are equipped with screens for the average service of most mediums ( steam, gas, air, oil, chemicals , ect. ).

The large screen open area ensures an efficient filtering action with a low pressure drop.

Filtering area to inlet area ratio is larger than 3 to 1 . Screens area manufactured with perforated plate in the materials and with the perforation specified in the relevant tables .

Screens with different perforation ( or wire mesh ) and materials may be manufactured on request.



## INSTALLATION

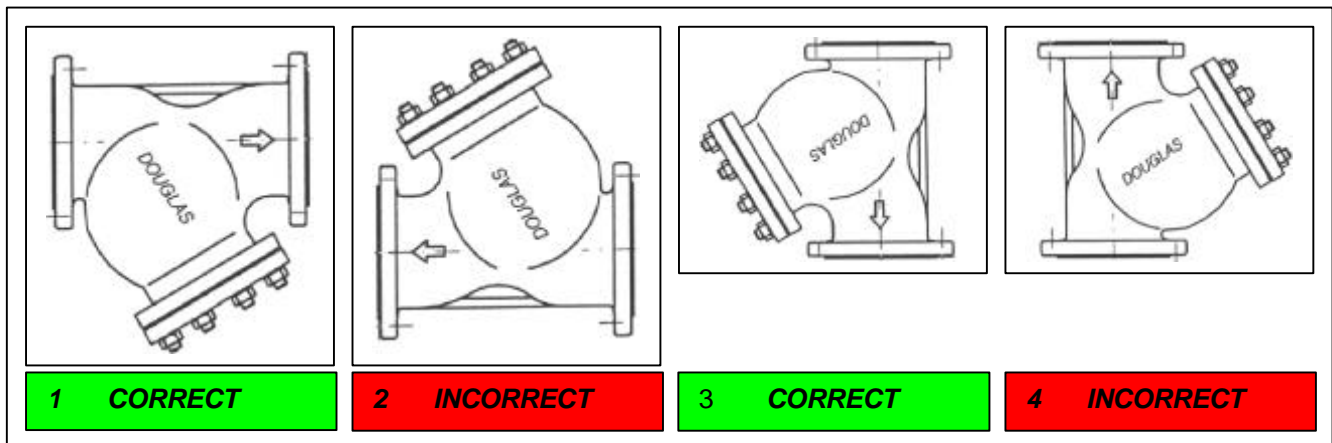

- All strainers should be mounted as close as possible to the valve or machinery which they are being installed to protect. It is important to ensure that the strainer installed with the flow following the same direction as the flow direction arrow cast onto the strainer body.
- For mounting in horizontal or inclined pipelines, ensure that the screen housing is always mounted below the pipeline.
- "Y" – strainers should never be installed in vertical pipelines in the upward flow condition. ( see above )

### SIZES

2"-3"-4"-6"-8"-10"-12"-14"-16"-18"-20"-24"

### CONNECTIONS

Buttweld	ANSI B16.25
Flanged	ANSI B 16.5

### LIMITING CONDITIONS ( according to ISO 6552 )

According to the body rating ( ANSI B16.34 )  
C150 – ANSI 150  
OTHER RATINGS ON REQUEST

## CAST STEEL " Y " TYPE STRAINERS DOUGLAS C150 CF8M

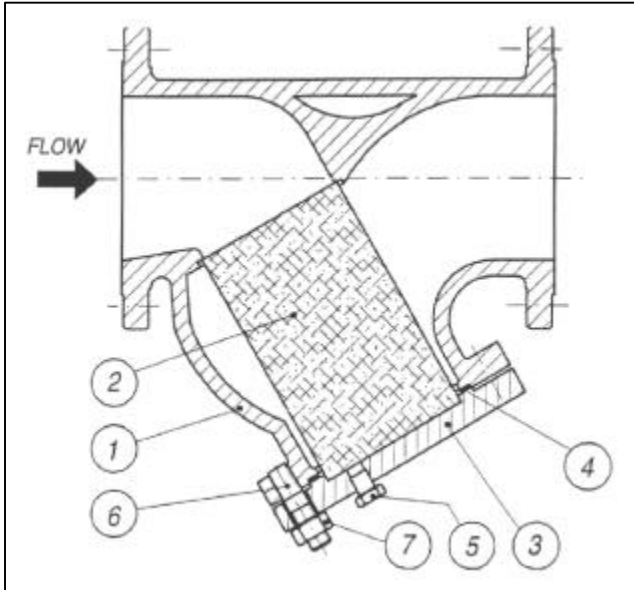

POS.	DESCRIPTION	MATERIALS	SPARES
1	Body	ASTM A351 CF8M	
2	Screen	S.S. 316	X
3	Cover	ASTM A240 316	
4	Gasket	316 / GRAPHITE	X
5	Drain plug	AISI 316	
6	Studs	ASTM A193 B8	
7	Nuts	ASTM A194 Gr.8	

OTHER MATERIALS ON REQUEST

Size (inches)	2"	3"	4"	6"	8"	10"	12"	14"	16"	18"	20"	24"
SRF	203	241	292	406	495	622	699	788	914	978	978	1295
S	203	241	292	406	495	622	699	788	914	978	978	1295
H	140	210	270	360	460	570	700	770	870	975	1095	1300
H1	190	260	340	400	580	660	800	1200	1400	1530	1750	2040
Kg	14	26	40	68	140	190	270	350	640	700	895	1370

STANDARD PERFORATIONS 1.5 mm  
SPECIAL PERFORATIONS ON REQUEST . DRAIN PLUG SIZE ¾"  
Dimension : SRF , S , H , H1 are in millimeters ( mm)

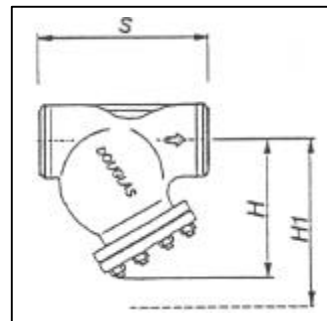
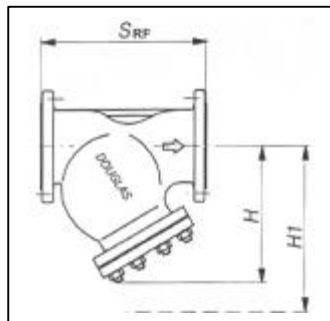

### HOW TO SERVICE

Strainer maintenance should be made at least once year, or whenever the pressure drop is found to be in excess of the normal figures. A quick clean-up system, to made approximately once a month, is to blow-off small impurities trough the drain-plug (5). It is recommended to install a drain valve by a nipple to the drain hole to speed-up this operation. For a complete maintenance follow the points herebelow: **-1-** Be sure that the main line has been shut-off. **-2-** Untighten cover stud bolts (6) and nuts (7) and remove cover (3) and gasket (4). **-3-** Withdraw screen (2) and carefully inspect it for damages. If any hole in the screen is found abstracted, clean it with compressed air and / or any suitable tool. If the screen is broken in any part or out of shape, replace it with a new spare one. **Never reinstall a broken or distorted screen.** **-4-** Carefully clean the inside of the strainer body. **-5-** Fit a new gasket (4). **-6-** Install the new screen or the cleaned one (2). Be sure to center the screen in the upper seat. **-7-** Put in place cover (3). Be sure that drain plug (5) is closed. **-8-** Slowly give pressure to the line, checking for leakages. **-9-** Write on the strainer body the date of this maintenance operation.

**How to order: i.e.** C150 CF8M / 316 F 1.5 2" 150 RF

**DOUGLAS ITALIA S.p.A** Località Pradaglie – 29013 CARPANETO PIACENTINO ( PC )

OFFICIAL WEB SITE: [www.douglas-italia.com](http://www.douglas-italia.com)



## STRAINERS

Designed to ANSI B16.34 the strainer bodies are produced with a superior wallthickness for corrosion allowance.

Standard strainers are equipped with screens for the average service of most mediums ( steam, gas, air, oil, chemicals , ect. ).

The large screen open area ensures an efficient filtering action with a low pressure drop.

Filtering area to inlet area ratio is larger than 3 to 1 . Screens area manufactured with perforated plate in the materials and with the perforation specified in the relevant tables .

Screens with different perforation ( or wire mesh ) and materials may be manufactured on request.



## INSTALLATION

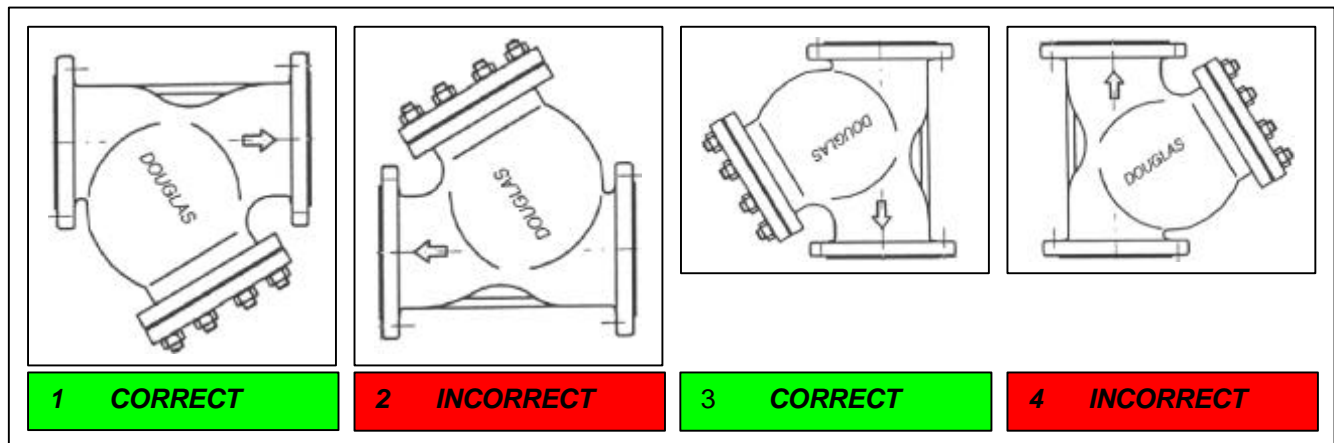

- All strainers should be mounted as close as possible to the valve or machinery which they are being installed to protect. It is important to ensure that the strainer installed with the flow following the same direction as the flow direction arrow cast onto the strainer body.
- For mounting in horizontal or inclined pipelines, ensure that the screen housing is always mounted below the pipeline.
- " Y " – strainers should never be installed in vertical pipelines in the upward flow condition. ( see above )

### SIZES

2"-3"-4"-6"-8"-10"-12"-14"-16"-18"-20"-24"

### CONNECTIONS

Buttweld	ANSI B16.25
Flanged	ANSI B 16.5

### LIMITING CONDITIONS ( according to ISO 6552 )

According to the body rating ( ANSI B16.34 )  
C300 – ANSI 300  
OTHER RATINGS ON REQUEST



## CAST STEEL " Y " TYPE STRAINERS DOUGLAS C300 WCB

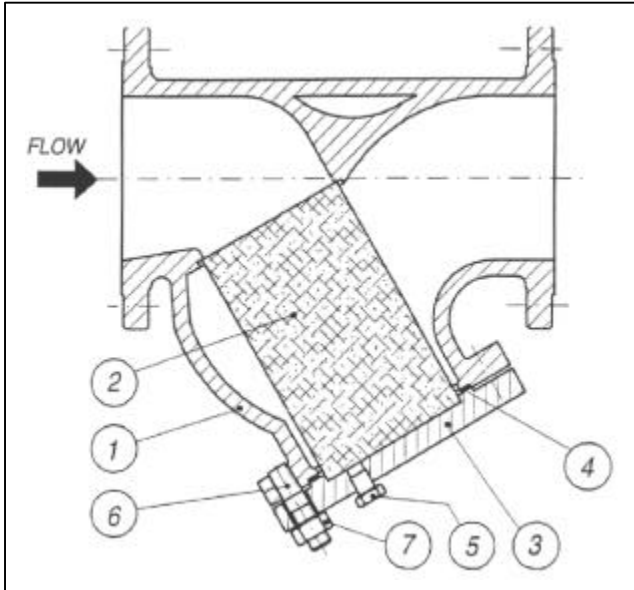

POS.	DESCRIPTION	MATERIALS	SPARES
1	Body	ASTM A216 WCB	
2	Screen	S.S. 304	X
3	Cover	ASTM A105	
4	Gasket	316 / GRAPHITE	X
5	Drain plug	ASTM A105	
6	Studs	ASTM A193 B7	
7	Nuts	ASTM A194 2H	

OTHER MATERIALS ON REQUEST

Size (inches)	2"	3"	4"	6"	8"	10"	12"	14"	16"	18"	20"	24"
SRF	267	318	356	445	559	622	711	838	864	978	1016	1346
S	267	318	356	445	559	622	711	838	864	978	1016	1346
H	175	240	330	380	500	625	740	805	920	1025	1140	1360
H1	250	275	360	470	575	920	1100	1200	1360	1350	1700	2050
Kg	20	45	65	105	180	254	430	670	750	863	1125	1625

STANDARD PERFORATIONS 1.5 mm  
SPECIAL PERFORATIONS ON REQUEST . DRAIN PLUG SIZE ¾"  
Dimension : SRF , S , H , H1 are in millimeters ( mm)

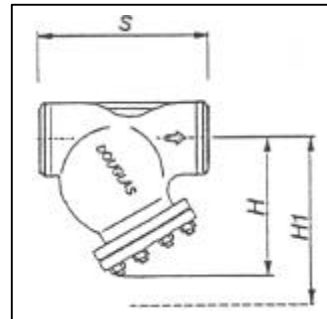
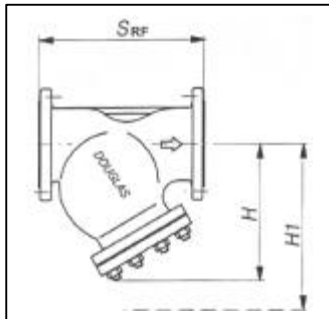

### HOW TO SERVICE

Strainer maintenance should be made at least once year, or whenever the pressure drop is found to be in excess of the normal figures. A quick clean-up system, to made approximately once a month, is to blow-off small impurities trough the drain-plug (5). It is recommended to install a drain valve by a nipple to the drain hole to speed-up this operation. For a complete maintenance follow the points herebelow: **-1-** Be sure that the main line has been shut-off. **-2-** Untighten cover stud bolts (6) and nuts (7) and remove cover (3) and gasket (4). **-3-** Withdraw screen (2) and carefully inspect it for damages. If any hole in the screen is found abstracted, clean it with compressed air and / or any suitable tool. If the screen is broken in any part or out of shape, replace it with a new spare one. **Never reinstall a broken or distorted screen.** **-4-** Carefully clean the inside of the strainer body. **-5-** Fit a new gasket (4). **-6-** Install the new screen or the cleaned one (2). Be sure to center the screen in the upper seat. **-7-** Put in place cover (3). Be sure that drain plug (5) is closed. **-8-** Slowly give pressure to the line, checking for leakages. **-9-** Write on the strainer body the date of this maintenance operation.

**How to order: i.e.** C300 WCB / 304 F 1.5 2" 300 RF

**DOUGLAS ITALIA S.p.A** Località Pradaglie – 29013 CARPANETO PIACENTINO ( PC )

OFFICIAL WEB SITE: [www.douglas-italia.com](http://www.douglas-italia.com)

## STRAINERS

Designed to ANSI B16.34 the strainer bodies are produced with a superior wall thickness for corrosion allowance.

Standard strainers are equipped with screens for the average service of most mediums ( steam, gas, air, oil, chemicals , ect. ).

The large screen open area ensures an efficient filtering action with a low pressure drop.

Filtering area to inlet area ratio is larger than 3 to 1 . Screens area manufactured with perforated plate in the materials and with the perforation specified in the relevant tables .

Screens with different perforation ( or wire mesh ) and materials may be manufactured on request.



## INSTALLATION

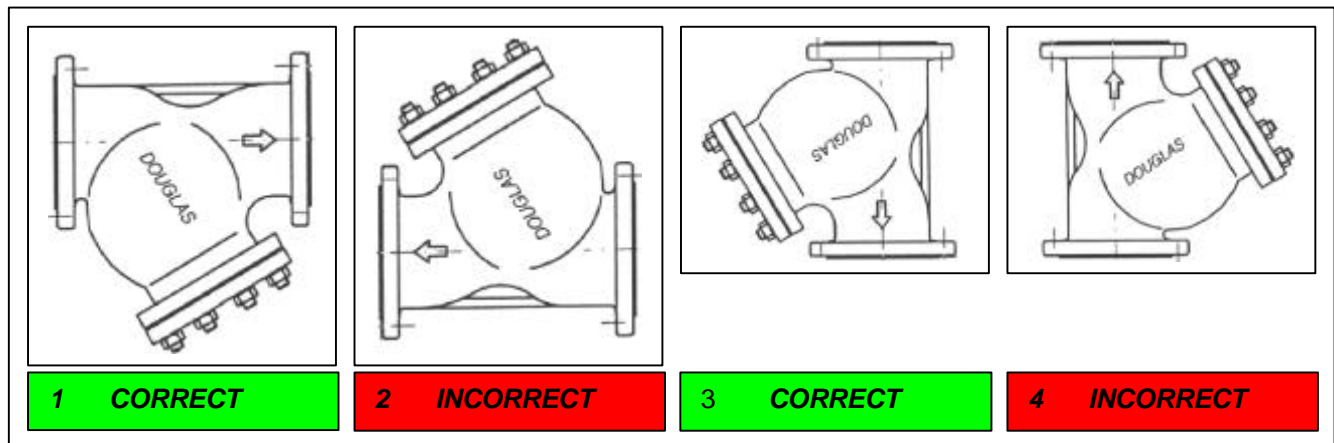

- All strainers should be mounted as close as possible to the valve or machinery which they are being installed to protect. It is important to ensure that the strainer installed with the flow following the same direction as the flow direction arrow cast onto the strainer body.
- For mounting in horizontal or inclined pipelines, ensure that the screen housing is always mounted below the pipeline.
- " Y " – strainers should never be installed in vertical pipelines in the upward flow condition. ( see above )

### SIZES

2"-3"-4"-6"-8"-10"-12"-14"-16"-18"-20"-24"

### CONNECTIONS

Buttweld	ANSI B16.25
Flanged	ANSI B 16.5

### LIMITING CONDITIONS ( according to ISO 6552 )

According to the body rating ( ANSI B16.34 )  
C300 – ANSI 300  
OTHER RATINGS ON REQUEST

## CAST STEEL " Y " TYPE STRAINERS DOUGLAS C300 CF8M

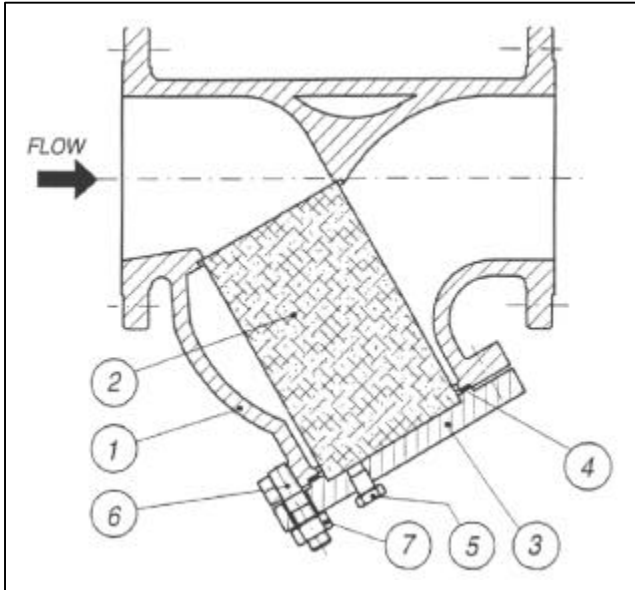

POS.	DESCRIPTION	MATERIALS	SPARES
1	Body	ASTM A351 CF8M	
2	Screen	S.S. 316	X
3	Cover	ASTM A240 316	
4	Gasket	316 / GRAPHITE	X
5	Drain plug	AISI 316	
6	Studs	ASTM A193 B8	
7	Nuts	ASTM A194 Gr.8	

OTHER MATERIALS ON REQUEST

Size (inches)	2"	3"	4"	6"	8"	10"	12"	14"	16"	18"	20"	24"
SRF	267	318	356	445	559	622	711	838	864	978	1016	1346
S	267	318	356	445	559	622	711	838	864	978	1016	1346
H	175	240	330	380	500	625	740	805	920	1025	1140	1360
H1	250	275	360	470	575	920	1100	1200	1360	1350	1700	2050
Kg	20	45	65	105	180	254	430	670	750	863	1125	1625

STANDARD PERFORATIONS 1.5 mm  
SPECIAL PERFORATIONS ON REQUEST . DRAIN PLUG SIZE ¾"  
Dimension : SRF , S , H , H1 are in millimeters ( mm)

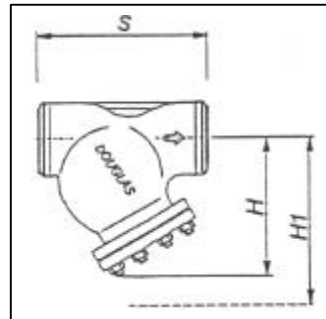
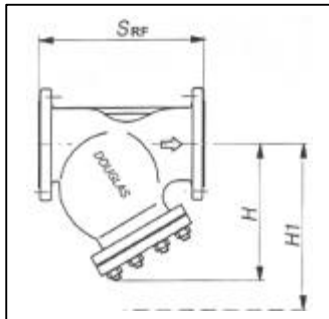

### HOW TO SERVICE

Strainer maintenance should be made at least once year, or whenever the pressure drop is found to be in excess of the normal figures. A quick clean-up system, to made approximately once a month, is to blow-off small impurities trough the drain-plug (5). It is recommended to install a drain valve by a nipple to the drain hole to speed-up this operation. For a complete maintenance follow the points herebelow: **-1-** Be sure that the main line has been shut-off. **-2-** Untighten cover stud bolts (6) and nuts (7) and remove cover (3) and gasket (4). **-3-** Withdraw screen (2) and carefully inspect it for damages. If any hole in the screen is found abstracted, clean it with compressed air and / or any suitable tool. If the screen is broken in any part or out of shape, replace it with a new spare one. **Never reinstall a broken or distorted screen.** **-4-** Carefully clean the inside of the strainer body. **-5-** Fit a new gasket (4). **-6-** Install the new screen or the cleaned one (2). Be sure to center the screen in the upper seat. **-7-** Put in place cover (3). Be sure that drain plug (5) is closed. **-8-** Slowly give pressure to the line, checking for leakages. **-9-** Write on the strainer body the date of this maintenance operation.

**How to order: i.e.** C300 CF8M / 316 F 1.5 2" 300 RF

**DOUGLAS ITALIA S.p.A** Località Pradaglie – 29013 CARPANETO PIACENTINO ( PC )

OFFICIAL WEB SITE: [www.douglas-italia.com](http://www.douglas-italia.com)

## STRAINERS

Designed to ANSI B16.34 the strainer bodies are produced with a superior wallthickness for corrosion allowance.

Standard strainers are equipped with screens for the average service of most mediums ( steam, gas, air, oil, chemicals , ect. ).

The large screen open area ensures an efficient filtering action with a low pressure drop.

Filtering area to inlet area ratio is larger than 3 to 1 . Screens area manufactured with perforated plate in the materials and with the perforation specified in the relevant tables .

Screens with different perforation ( or wire mesh ) and materials may be manufactured on request.



## INSTALLATION

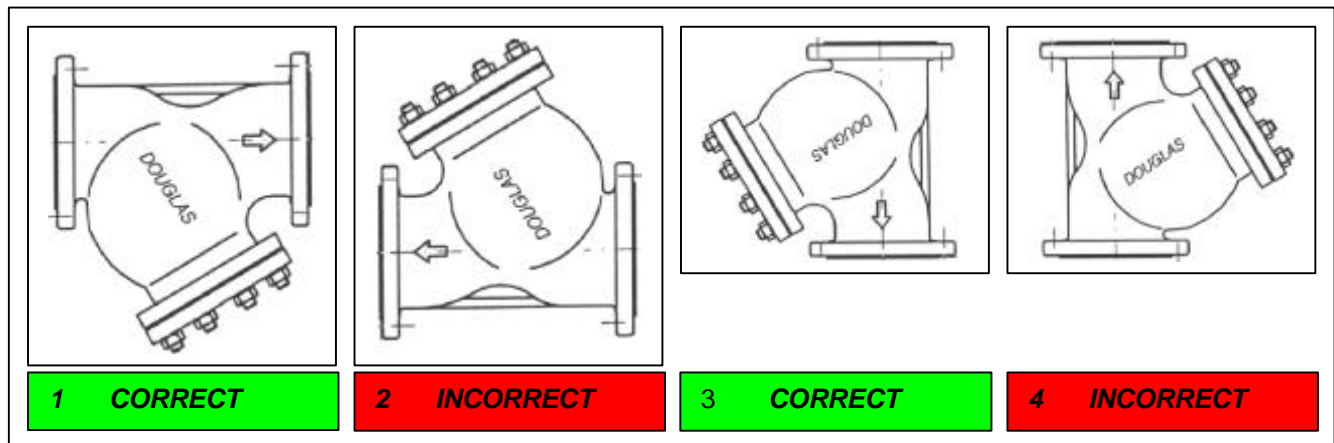

- All strainers should be mounted as close as possible to the valve or machinery which they are being installed to protect. It is important to ensure that the strainer installed with the flow following the same direction as the flow direction arrow cast onto the strainer body.
- For mounting in horizontal or inclined pipelines, ensure that the screen housing is always mounted below the pipeline.
- " Y " – strainers should never be installed in vertical pipelines in the upward flow condition. ( see above )

### SIZES

2"-3"-4"-6"-8"-10"-12"-14"-16"

### CONNECTIONS

Buttweld	ANSI B16.25
Flanged	ANSI B 16.5

### LIMITING CONDITIONS ( according to ISO 6552 )

According to the body rating ( ANSI B16.34 )  
C600 – ANSI 600  
OTHER RATINGS ON REQUEST

## CAST STEEL " Y " TYPE STRAINERS DOUGLAS C600 WCB

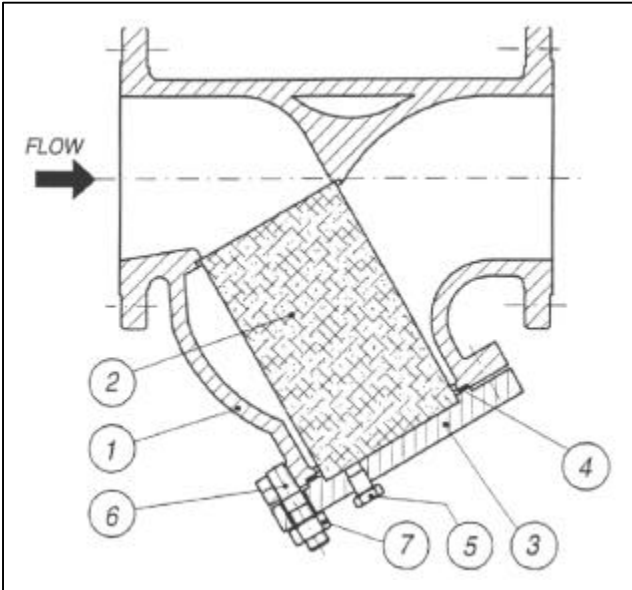

POS.	DESCRIPTION	MATERIALS	SPARES
1	Body	ASTM A216 WCB	
2	Screen	S.S. 304	X
3	Cover	ASTM A105	
4	Gasket	316 / GRAPHITE	X
5	Drain plug	ASTM A105	
6	Studs	ASTM A193 B7	
7	Nuts	ASTM A194 2H	

OTHER MATERIALS ON REQUEST

Size (inches)	2"	3"	4"	6"	8"	10"	12"	14"	16"
<b>SRTJ</b>	295	259	435	562	663	790	841	892	994
<b>SRF</b>	292	356	432	559	660	787	838	889	991
<b>S</b>	292	356	432	559	660	787	838	889	991
<b>H</b>	193	260	310	400	500	600	720	865	1180
<b>H1</b>	270	320	400	530	650	790	1200	1420	1520
<b>Kg</b>	35	60	95	230	400	590	700	770	1140

STANDARD PERFORATIONS 1.5 mm  
SPECIAL PERFORATIONS ON REQUEST . DRAIN PLUG SIZE ¾"  
Dimension : SRF , S , H , H1 are in millimeters ( mm)

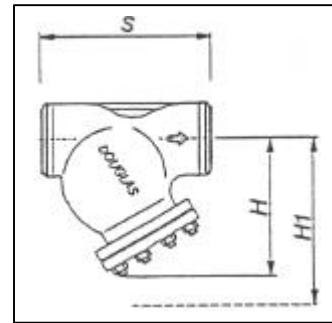
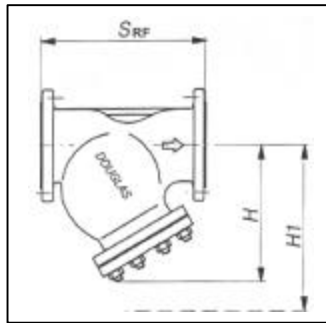
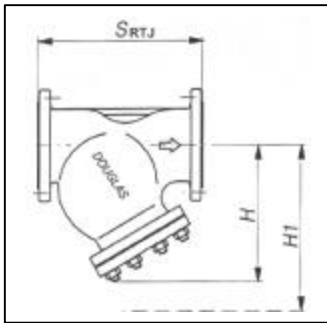

### HOW TO SERVICE

Strainer maintenance should be made at least once year, or whenever the pressure drop is found to be in excess of the normal figures. A quick clean-up system, to made approximately once a month, is to blow-off small impurities trough the drain-plug (5). It is recommended to install a drain valve by a nipple to the drain hole to speed-up this operation. For a complete maintenance follow the points herebelow: **-1-** Be sure that the main line has been shut-off. **-2-** Untighten cover stud bolts (6) and nuts (7) and remove cover (3) and gasket (4). **-3-** Withdraw screen (2) and carefully inspect it for damages. If any hole in the screen is found obstructed, clean it with compressed air and / or any suitable tool. If the screen is broken in any part or out of shape, replace it with a new spare one. **Never reinstall a broken or distorted screen.** **-4-** Carefully clean the inside of the strainer body. **-5-** Fit a new gasket (4). **-6-** Install the new screen or the cleaned one (2). Be sure to center the screen in the upper seat. **-7-** Put in place cover (3). Be sure that drain plug (5) is closed. **-8-** Slowly give pressure to the line, checking for leakages. **9-** Write on the strainer body the date of this maintenance operation.

**How to order: i.e.** C600 WCB / 304 F 1.5 2" 600 RTJ

**DOUGLAS ITALIA S.p.A** Località Pradaglie – 29013 CARPANETO PIACENTINO ( PC )

OFFICIAL WEB SITE: [www.douglas-italia.com](http://www.douglas-italia.com)



## STRAINERS

Designed to ANSI B16.34 the strainer bodies are produced with a superior wallthickness for corrosion allowance.

Standard strainers are equipped with screens for the average service of most mediums ( steam, gas, air, oil, chemicals , ect. ).

The large screen open area ensures an efficient filtering action with a low pressure drop.

Filtering area to inlet area ratio is larger than 3 to 1 .  
Screens area manufactured with perforated plate in the materials and with the perforation specified in the relevant tables .

Screens with different perforation ( or wire mesh ) and materials may be manufactured on request.



## INSTALLATION

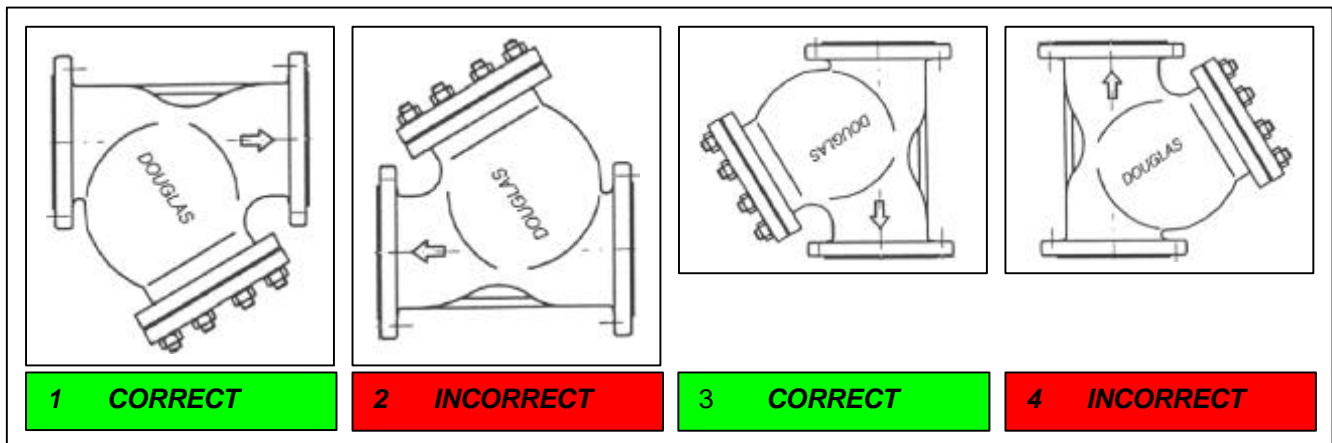

- All strainers should be mounted as close as possible to the valve or machinery which they are being installed to protect. It is important to ensure that the strainer installed with the flow following the same direction as the flow direction arrow cast onto the strainer body.
- For mounting in horizontal or inclined pipelines, ensure that the screen housing is always mounted below the pipeline.
- " Y " – strainers should never be installed in vertical pipelines in the upward flow condition. ( see above )

### SIZES

2"-3"-4"-6"-8"-10"-12"-14"-16"

### CONNECTIONS

Buttweld	ANSI B16.25
Flanged	ANSI B 16.5

### LIMITING CONDITIONS ( according to ISO 6552 )

According to the body rating ( ANSI B16.34 )  
C600 – ANSI 600  
OTHER RATINGS ON REQUEST

## CAST STEEL " Y " TYPE STRAINERS DOUGLAS C600 CF8M

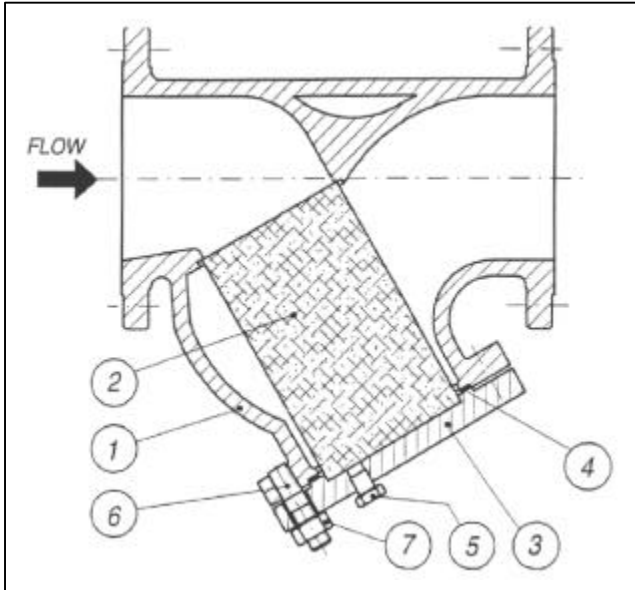

POS.	DESCRIPTION	MATERIALS	SPARES
1	Body	ASTM A351 CF8M	
2	Screen	S.S. 316	X
3	Cover	ASTM A240 316	
4	Gasket	316 / GRAPHITE	X
5	Drain plug	AISI 316	
6	Studs	ASTM A193 B8	
7	Nuts	ASTM A194 Gr.8	

OTHER MATERIALS ON REQUEST

Size (inches)	2"	3"	4"	6"	8"	10"	12"	14"	16"
<b>SRTJ</b>	295	259	435	562	663	790	841	892	994
<b>SRF</b>	292	356	432	559	660	787	838	889	991
<b>S</b>	292	356	432	559	660	787	838	889	991
<b>H</b>	193	260	310	400	500	600	720	865	1180
<b>H1</b>	270	320	400	530	650	790	1200	1420	1520
<b>Kg</b>	35	60	95	230	400	590	700	770	1140

STANDARD PERFORATIONS 1.5 mm  
SPECIAL PERFORATIONS ON REQUEST . DRAIN PLUG SIZE 3/4"  
Dimension : SRF , S , H , H1 are in millimeters ( mm)

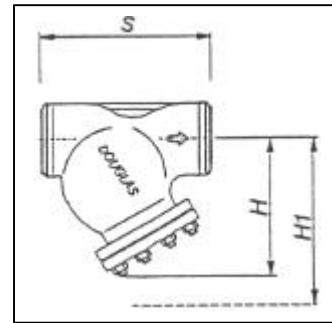
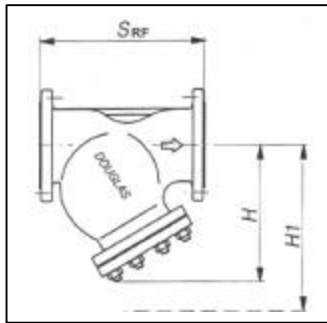
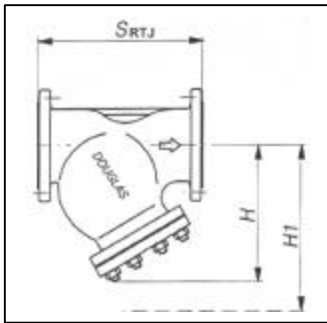

### HOW TO SERVICE

Strainer maintenance should be made at least once year, or whenever the pressure drop is found to be in excess of the normal figures. A quick clean-up system, to made approximately once a month, is to blow-off small impurities trough the drain-plug (5). It is recommended to install a drain valve by a nipple to the drain hole to speed-up this operation. For a complete maintenance follow the points herebelow: **-1-** Be sure that the main line has been shut-off. **-2-** Untighten cover stud bolts (6) and nuts (7) and remove cover (3) and gasket (4). **-3-** Withdraw screen (2) and carefully inspect it for damages. If any hole in the screen is found obstructed, clean it with compressed air and / or any suitable tool. If the screen is broken in any part or out of shape, replace it with a new spare one. **Never reinstall a broken or distorted screen.** **-4-** Carefully clean the inside of the strainer body. **-5-** Fit a new gasket (4). **-6-** Install the new screen or the cleaned one (2). Be sure to center the screen in the upper seat. **-7-** Put in place cover (3). Be sure that drain plug (5) is closed. **-8-** Slowly give pressure to the line, checking for leakages. **9-** Write on the strainer body the date of this maintenance operation.

**How to order: i.e.** C600 CF8M / 316 F 1.5 2" 600 RF

**DOUGLAS ITALIA S.p.A** Località Pradaglie – 29013 CARPANETO PIACENTINO ( PC )

OFFICIAL WEB SITE: [www.douglas-italia.com](http://www.douglas-italia.com)

## STRAINERS

Designed to ANSI B16.34 the strainer bodies are produced with a superior wallthickness for corrosion allowance.

Standard stainers are equipped with screens for the average service of most mediums ( steam, gas, air, oil, chemicals , ect. ).

The large screen open area ensures an efficient filtering action with a low pressure drop.

Filtering area to inlet area ratio is larger than 3 to 1 . Screens area manufactured with perforated plate in the materials and with the perforation specified in the relevant tables .

Screens with different peforation ( or wire mesh ) and materials may be manufactured on request.



## INSTALLATION

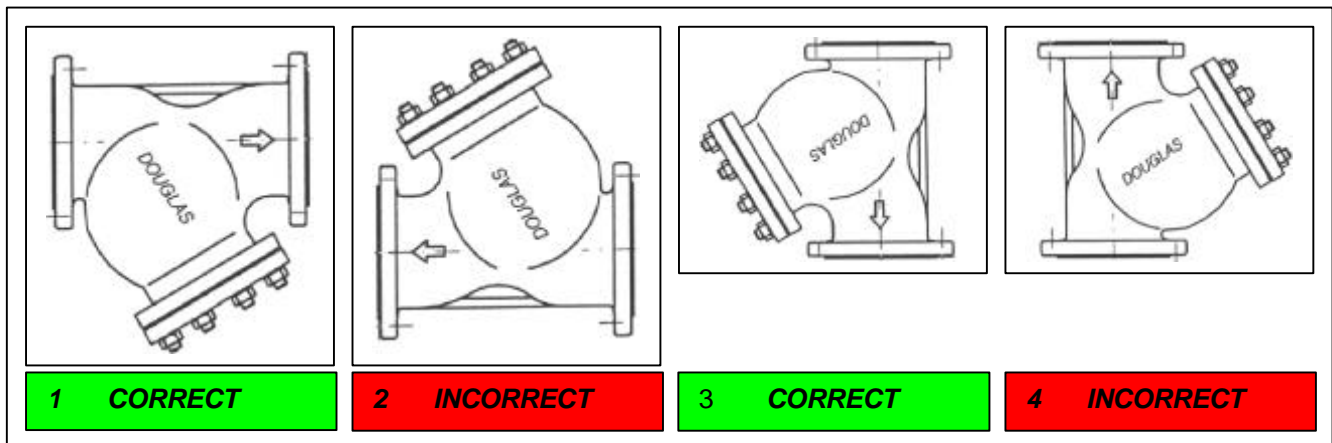

- All strainers should be mounted as close as possible to the valve or machinery which they are being installed to protect. It is important to ensure that the strainer installed with the flow following the same direction as the flow direction arrow cast onto the strainer body.
- For mounting in horizontal or inclined pipelines, ensure that the screen housing is always mounted below the pipeline.
- " Y " – strainers should never be installed in vertical pipelines in the upward flow condition. ( see above )

### SIZES

2"-3"-4"-6"-8"-10"-12"

### CONNECTIONS

Buttweld	ANSI B16.25
Flanged	ANSI B 16.5

### LIMITING CONDITIONS ( according to ISO 6552 )

According to the body rating ( ANSI B16.34 )  
C900 – ANSI 900  
OTHER RATINGS ON REQUEST

## CAST STEEL " Y " TYPE STRAINERS DOUGLAS C900 WCB

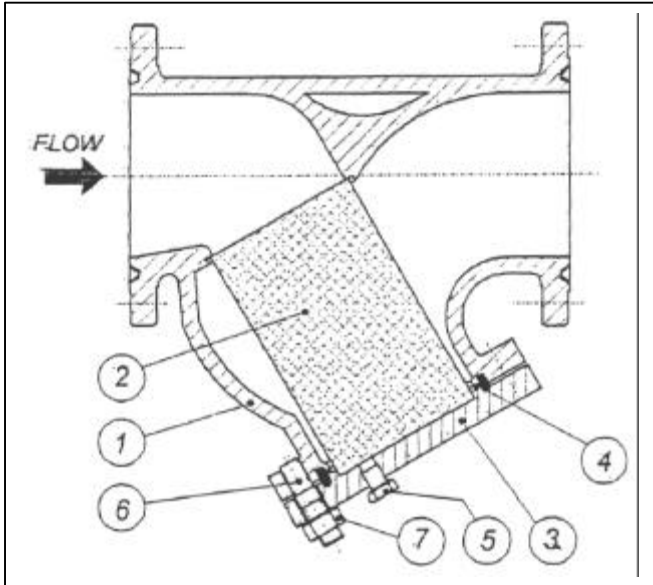

POS.	DESCRIPTION	MATERIALS	SPARES
1	Body	ASTM A216 WCB	
2	Screen	S.S. 304	X
3	Cover	ASTM A105	
4	Gasket RJ	ARMCO	X
5	Drain plug	ASTM A105	
6	Studs	ASTM A193 B7	
7	Nuts	ASTM A194 2H	

OTHER MATERIALS ON REQUEST

Size (inches)	2"	3"	4"	6"	8"	10"	12"
<b>SRTJ</b>	371	384	460	613	740	841	968
<b>SRF</b>	368	381	457	610	737	838	965
<b>S</b>	368	381	457	610	737	838	965
<b>H</b>	250	295	375	555	665	650	650
<b>H1</b>	400	320	435	630	780	890	976
<b>Kg</b>	55	83	155	261	600	1494	1750

STANDARD PERFORATIONS 1.5 mm  
SPECIAL PERFORATIONS ON REQUEST. DRAIN PLUG SIZE 3/4"  
Dimension : SRF, S, H, H1 are in millimeters ( mm)

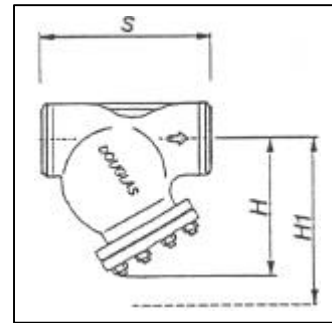
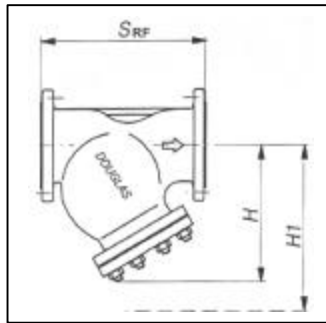
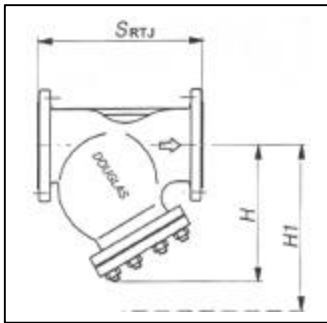

### HOW TO SERVICE

Strainer maintenance should be made at least once year, or whenever the pressure drop is found to be in excess of the normal figures. A quick clean-up system, to made approximately once a month, is to blow-off small impurities trough the drain-plug (5). It is recommended to install a drain valve by a nipple to the drain hole to speed-up this operation. For a complete maintenance follow the points herebelow: **-1-** Be sure that the main line has been shut-off. **-2-** Untighten cover stud bolts (6) and nuts (7) and remove cover (3) and gasket (4). **-3-** Withdraw screen (2) and carefully inspect it for damages. If any hole in the screen is found obstructed, clean it with compressed air and / or any suitable tool. If the screen is broken in any part or out of shape, replace it with a new spare one. **Never reinstall a broken or distorted screen.** **-4-** Carefully clean the inside of the strainer body. **-5-** Fit a new gasket (4). **-6-** Install the new screen or the cleaned one (2). Be sure to center the screen in the upper seat. **-7-** Put in place cover (3). Be sure that drain plug (5) is closed. **-8-** Slowly give pressure to the line, checking for leakages. **9-** Write on the strainer body the date of this maintenance operation.

**How to order: i.e.** C900 WCB / 304 F 1.5 2" 900 RTJ

**DOUGLAS ITALIA S.p.A** Località Pradaglie – 29013 CARPANETO PIACENTINO ( PC )

OFFICIAL WEB SITE: [www.douglas-italia.com](http://www.douglas-italia.com)



## STRAINERS

Designed to ANSI B16.34 the strainer bodies are produced with a superior wallthickness for corrosion allowance.

Standard stainers are equipped with screens for the average service of most mediums ( steam, gas, air, oil, chemicals , ect. ).

The large screen open area ensures an efficient filtering action with a low pressure drop.

Filtering area to inlet area ratio is larger than 3 to 1 . Screens area manufactured with perforated plate in the materials and with the perforation specified in the relevant tables .

Screens with different peforation ( or wire mesh ) and materials may be manufactured on request.



## INSTALLATION

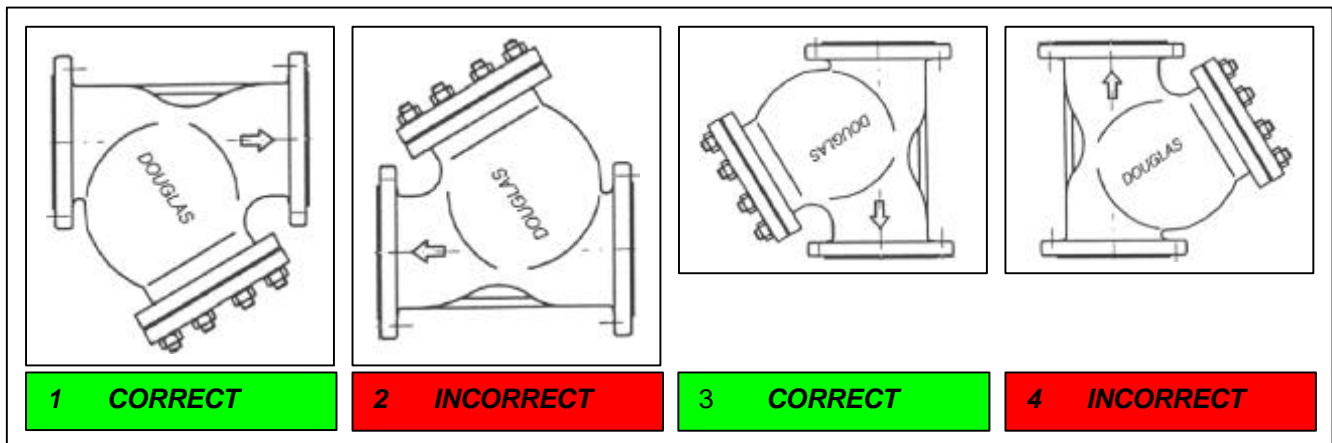

- All strainers should be mounted as close as possible to the valve or machinery which they are being installed to protect. It is important to ensure that the strainer installed with the flow following the same direction as the flow direction arrow cast onto the strainer body.
- For mounting in horizontal or inclined pipelines, ensure that the screen housing is always mounted below the pipeline.
- " Y " – strainers should never be installed in vertical pipelines in the upward flow condition. ( see above )

### SIZES

2"-3"-4"-6"-8"-10"-12"

### CONNECTIONS

Buttweld	ANSI B16.25
Flanged	ANSI B 16.5

### LIMITING CONDITIONS ( according to ISO 6552 )

According to the body rating ( ANSI B16.34 )  
C900 – ANSI 900  
OTHER RATINGS ON REQUEST



## CAST STEEL " Y " TYPE STRAINERS DOUGLAS C900 CF8M

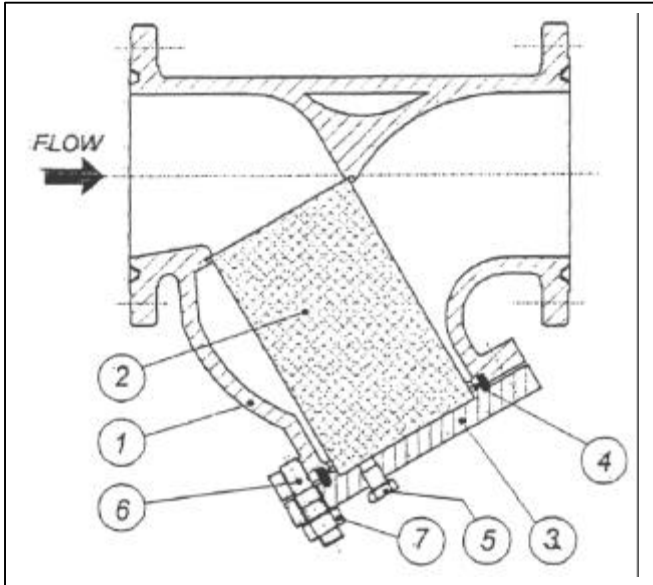

POS.	DESCRIPTION	MATERIALS	SPARES
1	Body	ASTM A351 CF8M	
2	Screen	S.S. 316	X
3	Cover	ASTM A240 316	
4	Gasket RJ	F316	X
5	Drain plug	AISI 316	
6	Studs	ASTM A193 B8	
7	Nuts	ASTM A194 Gr.8	

OTHER MATERIALS ON REQUEST

Size (inches)	2"	3"	4"	6"	8"	10"	12"
<b>SRTJ</b>	371	384	460	613	740	841	968
<b>SRF</b>	368	381	457	610	737	838	965
<b>S</b>	368	381	457	610	737	838	965
<b>H</b>	250	295	375	555	665	650	650
<b>H1</b>	400	320	435	630	780	890	976
<b>Kg</b>	55	83	155	261	600	1494	1750

STANDARD PERFORATIONS 1.5 mm  
SPECIAL PERFORATIONS ON REQUEST. DRAIN PLUG SIZE 3/4"  
Dimension : SRF, S, H, H1 are in millimeters ( mm)

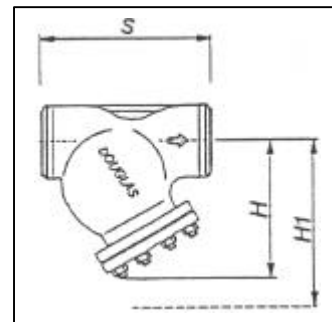
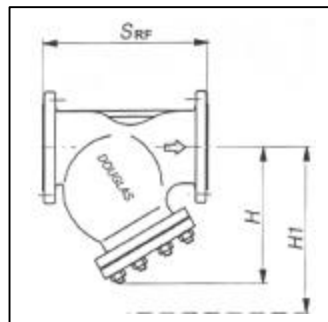
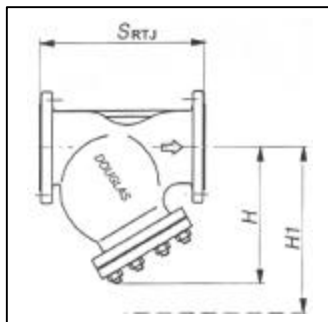

### HOW TO SERVICE

Strainer maintenance should be made at least once year, or whenever the pressure drop is found to be in excess of the normal figures. A quick clean-up system, to made approximately once a month, is to blow-off small impurities trough the drain-plug (5). It is recommended to install a drain valve by a nipple to the drain hole to speed-up this operation. For a complete maintenance follow the points herebelow: **-1-** Be sure that the main line has been shut-off. **-2-** Untighten cover stud bolts (6) and nuts (7) and remove cover (3) and gasket (4). **-3-** Withdraw screen (2) and carefully inspect it for damages. If any hole in the screen is found obstructed, clean it with compressed air and / or any suitable tool. If the screen is broken in any part or out of shape, replace it with a new spare one. **Never reinstall a broken or distorted screen.** **-4-** Carefully clean the inside of the strainer body. **-5-** Fit a new gasket (4). **-6-** Install the new screen or the cleaned one (2). Be sure to center the screen in the upper seat. **-7-** Put in place cover (3). Be sure that drain plug (5) is closed. **-8-** Slowly give pressure to the line, checking for leakages. **9-** Write on the strainer body the date of this maintenance operation.

**How to order: i.e.** C900 CF8M / 316 F 1.5 2" 900 RTJ

**DOUGLAS ITALIA S.p.A** Località Pradaglie – 29013 CARPANETO PIACENTINO ( PC )

OFFICIAL WEB SITE: [www.douglas-italia.com](http://www.douglas-italia.com)

## STRAINERS

Designed to ANSI B16.34 the strainer bodies are produced with a superior wallthickness for corrosion allowance.

Standard strainers are equipped with screens for the average service of most mediums ( steam, gas, air, oil, chemicals , ect. ).

The large screen open area ensures an efficient filtering action with a low pressure drop.

Filtering area to inlet area ratio is larger than 3 to 1 .  
Screens area manufactured with perforated plate in the materials and with the perforation specified in the relevant tables .

Screens with different perforation ( or wire mesh ) and materials may be manufactured on request.



## INSTALLATION

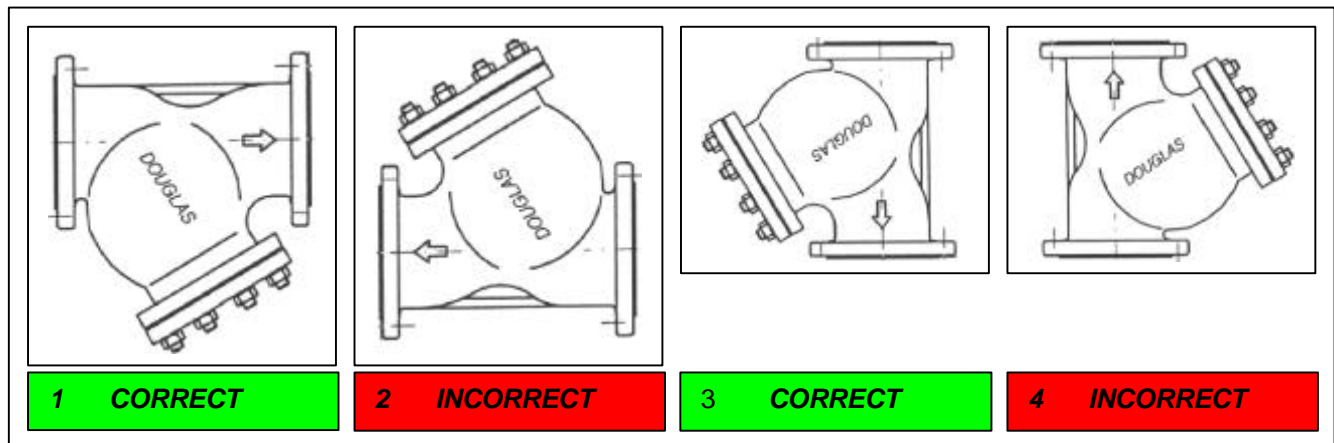

- All strainers should be mounted as close as possible to the valve or machinery which they are being installed to protect. It is important to ensure that the strainer installed with the flow following the same direction as the flow direction arrow cast onto the strainer body.
- For mounting in horizontal or inclined pipelines, ensure that the screen housing is always mounted below the pipeline.
- " Y " – strainers should never be installed in vertical pipelines in the upward flow condition. ( see above )

### SIZES

16"

### CONNECTIONS

Buttweld	ANSI B16.25
Flanged	ANSI B 16.5

### LIMITING CONDITIONS ( according to ISO 6552 )

According to the body rating ( ANSI B16.34 )

C900 – ANSI 900

OTHER RATINGS ON REQUEST

## CAST STEEL " Y " TYPE PRESSURE SEAL STRAINERS C900 WCB

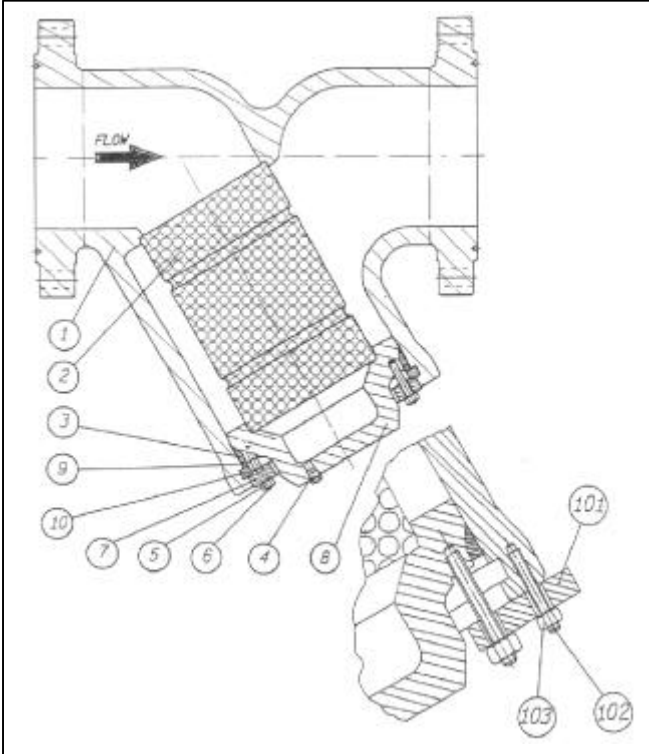

POS.	DESCRIPTION	MATERIALS	SPARES
1	Body	ASTM A216 WCB	
2	Screen	S.S. 304	X
3	Gasket	S.S. 304	X
4	Drain plug	A105	
5	Nuts	ASTM A194 2H	
6	Studs	ASTM A193 B7	
7	Sleeve	ASTM A105	
8	Cover	ASTM A105	
9	Ring	ASTM A182 F6	
10	Retain ring	ASTM A182 F6	

OTHER MATERIALS ON REQUEST

Size (inches)	16"
SRTJ	1140
SRF	1092
S	1092
H	865
H1	1340
Kg	-

STANDARD PERFORATIONS 1.5 mm  
SPECIAL PERFORATIONS ON REQUEST. DRAIN PLUG SIZE ¾"  
Dimension : SRF , S , H , H1 are in millimeters ( mm)

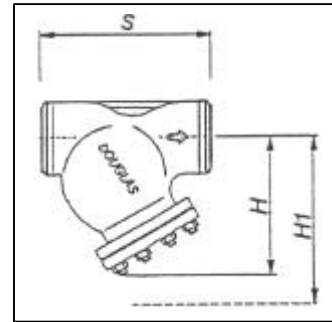
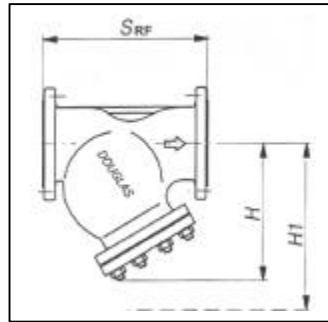
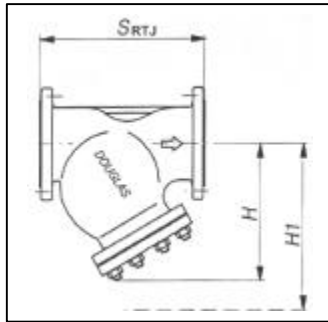

### HOW TO SERVICE

Strainer maintenance should be made at least once year, or whenever the pressure drop is found to be in excess of the normal figures. A quick clean-up system, to made approximately once a month, is to blow-off small impurities trough the drain-plug on cover (4). This operation is faster if a drain valve is installed. For a complete maintenance follow the points herebelow: -1- Be sure that the main line has been shut-off. -2- Untighten nuts (5) remove sleeve (7) and studs (6). -3- Remove retain ring (10) -4- Reinstall the studs (6) to the cover and install studs (102) into threaded holes drilled on the screen casing end. Install four shims (101) with nuts (5 and 103) as per enclosed drawing. -5- Tighten the nuts (5) driving the cover (8) against the shims (101). This will also extract the gasket (3) from its seat and them until the gasket (3) is completely extracted from its seat and the cover (8) can be withdraw from the body. -6- Withdraw screen (2) and carefully inspect it for damages. If any hole in the screen is found obstructed, clean it with compressed air and/or any suitable tool. If the screen is broken in any part or out of shape, replace it with a new spare one. **Never reinstall a broken or distorted screen.** -7- Carefully clean the inside of the strainer body. -8- Install the new screen or the old cleaned one (2). Be sure the center the screen in the upper seat. -9- Install the cover (8) without the studs (6) making sure the screen (2) fits correctly in the cover seat. Check that the cover (8) is fully inserted in the body to allow the installation of the retain ring (10). -10- Install a new gasket (3) and the spacer ring (9). -11- Install retaining ring (10) in their recess in the body, making sure that the holes are visible. -12- Place the sleeve (7) in contact with its seat on the body (1). -13- Slowly cross-tighten the nuts (5) taking care that the cover (8) is kept in axis with the body. This is easily checked watching the gap between the sleeve (7) hole and cover's (8) hub. -14- Slowly give pressure to the line, checking for leakages. -15- Write on the strainer body or tag the date of this maintenance operation.

**How to order:** i.e. C900 WCB / 304 F 1.5 16" 900 RTJ

**DOUGLAS ITALIA S.p.A** Località Pradaglie – 29013 CARPANETO PIACENTINO ( PC )

OFFICIAL WEB SITE: [www.douglas-italia.com](http://www.douglas-italia.com)

## STRAINERS

Designed to ANSI B16.34 the strainer bodies are produced with a superior wallthickness for corrosion allowance.

Standard strainers are equipped with screens for the average service of most mediums ( steam, gas, air, oil, chemicals , ect. ).

The large screen open area ensures an efficient filtering action with a low pressure drop.

Filtering area to inlet area ratio is larger than 3 to 1 .  
Screens area manufactured with perforated plate in the materials and with the perforation specified in the relevant tables .

Screens with different perforation ( or wire mesh ) and materials may be manufactured on request.



## INSTALLATION

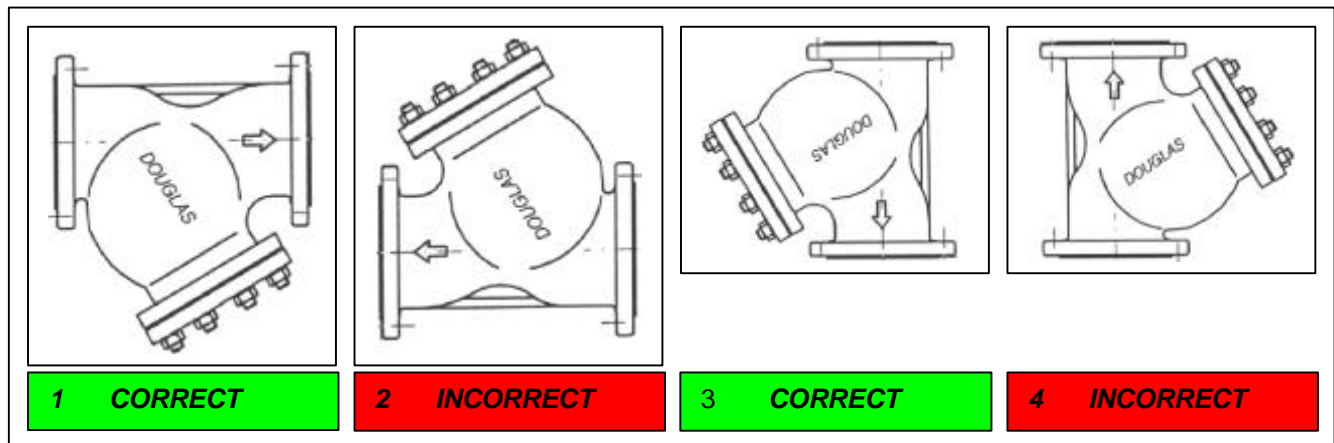

- All strainers should be mounted as close as possible to the valve or machinery which they are being installed to protect. It is important to ensure that the strainer installed with the flow following the same direction as the flow direction arrow cast onto the strainer body.
- For mounting in horizontal or inclined pipelines, ensure that the screen housing is always mounted below the pipeline.
- " Y " – strainers should never be installed in vertical pipelines in the upward flow condition. ( see above )

### SIZES

16"

### CONNECTIONS

Buttweld	ANSI B16.25
Flanged	ANSI B 16.5

### LIMITING CONDITIONS ( according to ISO 6552 )

According to the body rating ( ANSI B16.34 )

C900 – ANSI 900

OTHER RATINGS ON REQUEST



# CAST STEEL " Y " TYPE PRESSURE SEAL STRAINERS C900 CF8M

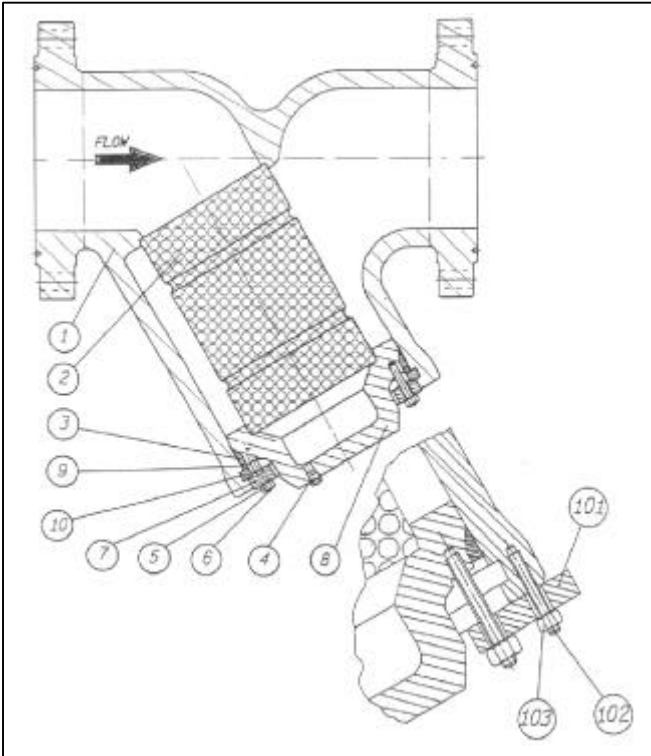

POS.	DESCRIPTION	MATERIALS	SPARES
1	Body	ASTM A351 CF8M	
2	Screen	S.S. 316	X
3	Gasket	A182 F316	X
4	Drain plug	S.S. 316	
5	Nuts	A194 Gr.8	
6	Studs	A193 B8	
7	Sleeve	A182 F316	
8	Cover	A182 F316	
9	Ring	A182 F6	
10	Retain ring	A182 F6	

OTHER MATERIALS ON REQUEST

Size (inches)	16"
SRTJ	1140
SRF	1092
S	1092
H	865
H1	1340
Kg	-

STANDARD PERFORATIONS 1.5 mm  
SPECIAL PERFORATIONS ON REQUEST. DRAIN PLUG SIZE ¾"  
Dimension : SRF , S , H , H1 are in millimeters ( mm)

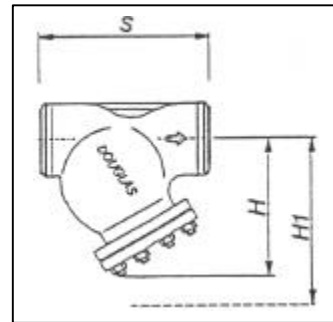
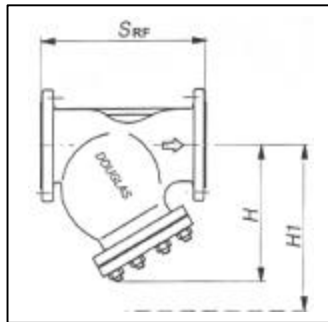
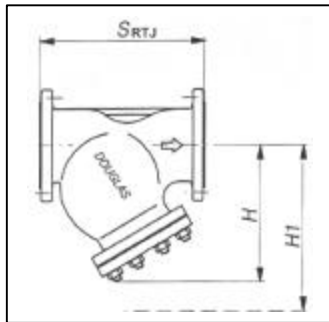

## HOW TO SERVICE

Strainer maintenance should be made at least once year, or whenever the pressure drop is found to be in excess of the normal figures. A quick clean-up system, to made approximately once a month, is to blow-off small impurities trough the drain-plug on cover (4). This operation is faster if a drain valve is installed. For a complete maintenance follow the points herebelow: -1- Be sure that the main line has been shut-off. -2- Untighten nuts (5) remove sleeve (7) and studs (6). -3- Remove retain ring (10) -4- Reinstall the studs (6) to the cover and install studs (102) into threaded holes drilled on the screen casing end. Install four shims (101) with nuts (5 and 103) as per enclosed drawing. -5- Tighten the nuts (5) driving the cover (8) against the shims (101). This will also extract the gasket (3) from its seat and them until the gasket (3) is completely extracted from its seat and the cover (8) can be withdraw from the body. -6- Withdraw screen (2) and carefully inspect it for damages. If any hole in the screen is found obstructed, clean it with compressed air and/or any suitable tool. If the screen is broken in any part or out of shape, replace it with a new spare one. **Never reinstall a broken or distorted screen.** -7- Carefully clean the inside of the strainer body. -8- Install the new screen or the old cleaned one (2). Be sure the center the screen in the upper seat. -9- Install the cover (8) without the studs (6) making sure the screen (2) fits correctly in the cover seat. Check that the cover (8) is fully inserted in the body to allow the installation of the retain ring (10). -10- Install a new gasket (3) and the spacer ring (9). -11- Install retaining ring (10) in their recess in the body, making sure that the holes are visible. -12- Place the sleeve (7) in contact with its seat on the body (1). -13- Slowly cross-tighten the nuts (5) taking care that the cover (8) is kept in axis with the body. This is easily checked watching the gap between the sleeve (7) hole and cover's (8) hub. -14- Slowly give pressure to the line, checking for leakages. -15- Write on the strainer body or tag the date of this maintenance operation.

**How to order: i.e.** C900 CF8M / 316 F 1.5 16" 900 RTJ

**DOUGLAS ITALIA S.p.A** Località Pradaglie – 29013 CARPANETO PIACENTINO ( PC )

OFFICIAL WEB SITE: [www.douglas-italia.com](http://www.douglas-italia.com)



## STRAINERS

Designed to ANSI B16.34 the strainer bodies are produced with a superior wallthickness for corrosion allowance.

Standard stainers are equipped with screens for the average service of most mediums ( steam, gas, air, oil, chemicals , ect. ).

The large screen open area ensures an efficient filtering action with a low pressure drop.

Filtering area to inlet area ratio is larger than 3 to 1 . Screens area manufactured with perforated plate in the materials and with the perforation specified in the relevant tables .

Screens with different peforation ( or wire mesh ) and materials may be manufactured on request.



## INSTALLATION

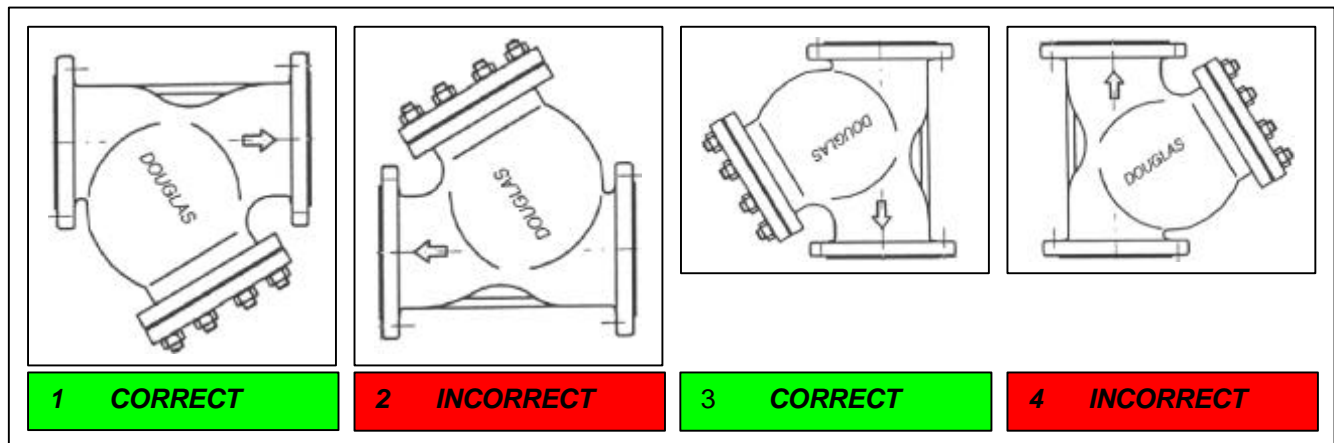

- All strainers should be mounted as close as possible to the valve or machinery which they are being installed to protect. It is important to ensure that the strainer installed with the flow following the same direction as the flow direction arrow cast onto the strainer body.
- For mounting in horizontal or inclined pipelines, ensure that the screen housing is always mounted below the pipeline.
- " Y " – strainers should never be installed in vertical pipelines in the upward flow condition. (see above )

### SIZES

2"-3"-4"-6"-8"

### CONNECTIONS

Buttweld	ANSI B16.25
Flanged	ANSI B 16.5

### LIMITING CONDITIONS ( according to ISO 6552 )

According to the body rating ( ANSI B16.34 )  
C1500 – ANSI 1500  
OTHER RATINGS ON REQUEST

## CAST STEEL " Y " TYPE STRAINERS DOUGLAS C1500 WCB

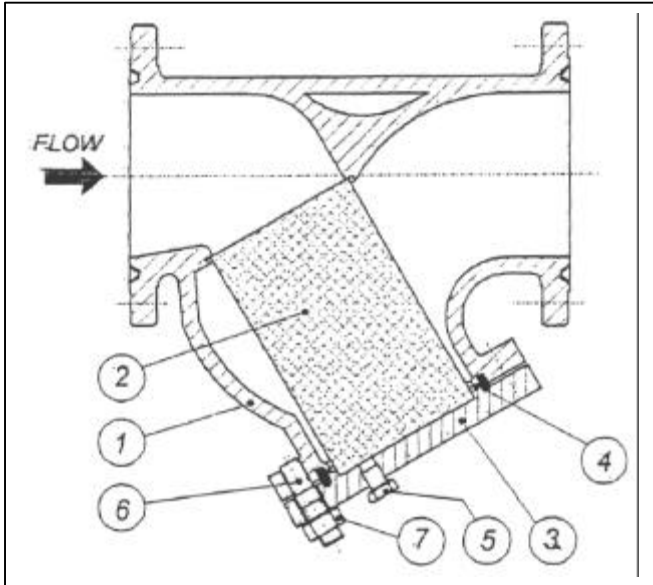

POS.	DESCRIPTION	MATERIALS	SPARES
1	Body	ASTM A216 WCB	
2	Screen	S.S. 304	X
3	Cover	ASTM A105	
4	Gasket RJ	ARMCO	X
5	Drain plug	ASTM A105	
6	Studs	ASTM A193 B7	
7	Nuts	ASTM A194 2H	

OTHER MATERIALS ON REQUEST

Size (inches)	2"	3"	4"	6"	8"
SRTJ	371	473	549	711.5	842
SRF	368	470	546	705	832
S	368	470	546	705	832
H	250	325	375	480	620
H1	400	540	600	750	900
Kg	60	100	160	400	600

STANDARD PERFORATIONS 1.5 mm  
SPECIAL PERFORATIONS ON REQUEST. DRAIN PLUG SIZE 3/4"  
Dimension : SRF, S, H, H1 are in millimeters ( mm)

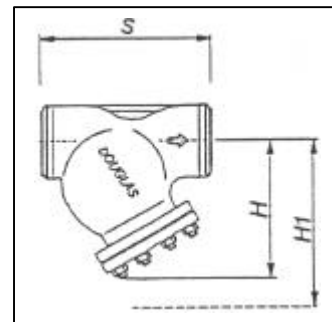
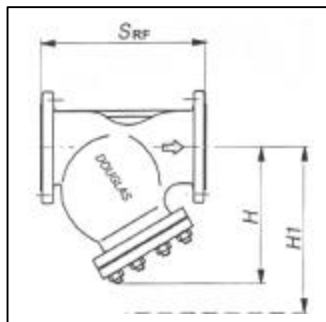
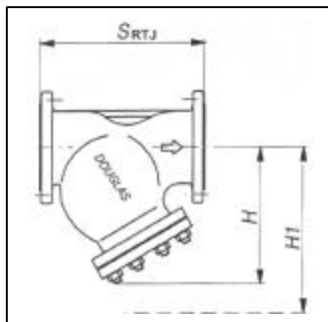

### HOW TO SERVICE

Strainer maintenance should be made at least once year, or whenever the pressure drop is found to be in excess of the normal figures. A quick clean-up system, to made approximately once a month, is to blow-off small impurities trough the drain-plug (5). It is recommended to install a drain valve by a nipple to the drain hole to speed-up this operation. For a complete maintenance follow the points herebelow: **-1-** Be sure that the main line has been shut-off. **-2-** Untighten cover stud bolts (6) and nuts (7) and remove cover (3) and gasket (4). **-3-** Withdraw screen (2) and carefully inspect it for damages. If any hole in the screen is found obstructed, clean it with compressed air and / or any suitable tool. If the screen is broken in any part or out of shape, replace it with a new spare one. **Never reinstall a broken or distorted screen.** **-4-** Carefully clean the inside of the strainer body. **-5-** Fit a new gasket (4). **-6-** Install the new screen or the cleaned one (2). Be sure to center the screen in the upper seat. **-7-** Put in place cover (3). Be sure that drain plug (5) is closed. **-8-** Slowly give pressure to the line, checking for leakages. **9-** Write on the strainer body the date of this maintenance operation.

**How to order: i.e.** C1500 WCB / 304 F 1.5 2" 900 RTJ

**DOUGLAS ITALIA S.p.A** Località Pradaglie – 29013 CARPANETO PIACENTINO ( PC )

OFFICIAL WEB SITE: [www.douglas-italia.com](http://www.douglas-italia.com)

## STRAINERS

Designed to ANSI B16.34 the strainer bodies are produced with a superior wallthickness for corrosion allowance.

Standard stainers are equipped with screens for the average service of most mediums ( steam, gas, air, oil, chemicals , ect. ).

The large screen open area ensures an efficient filtering action with a low pressure drop.

Filtering area to inlet area ratio is larger than 3 to 1 . Screens area manufactured with perforated plate in the materials and with the perforation specified in the relevant tables .

Screens with different peforation ( or wire mesh ) and materials may be manufactured on request.



## INSTALLATION

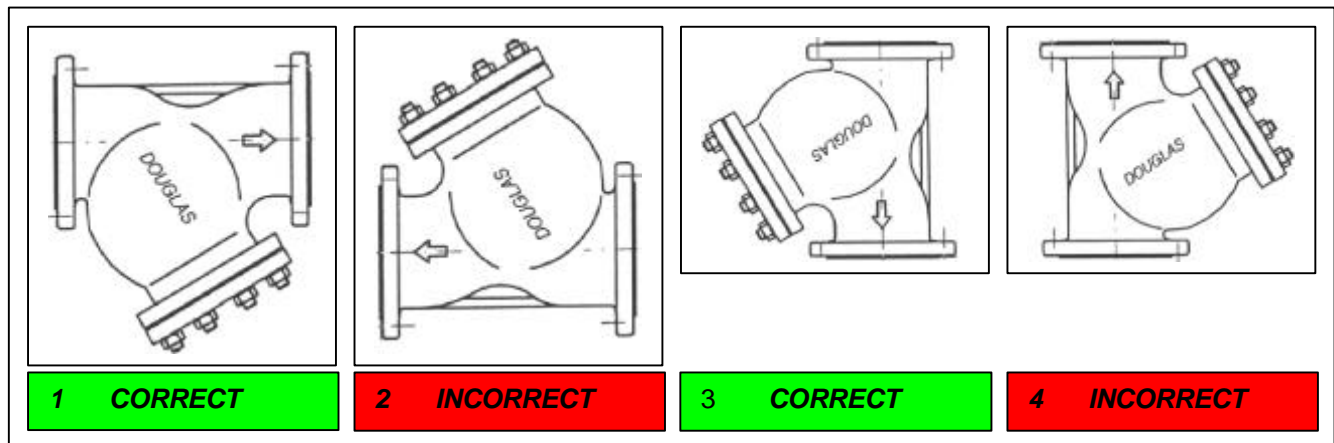

- All strainers should be mounted as close as possible to the valve or machinery which they are being installed to protect. It is important to ensure that the strainer installed with the flow following the same direction as the flow direction arrow cast onto the strainer body.
- For mounting in horizontal or inclined pipelines, ensure that the screen housing is always mounted below the pipeline.
- " Y " – strainers should never be installed in vertical pipelines in the upward flow condition ( see above )

### SIZES

2"-3"-4"-6"-8"

### CONNECTIONS

Buttweld	ANSI B16.25
Flanged	ANSI B 16.5

### LIMITING CONDITIONS ( according to ISO 6552 )

According to the body rating ( ANSI B16.34 )  
C1500 – ANSI 1500  
OTHER RATINGS ON REQUEST

## CAST STEEL " Y " TYPE STRAINERS DOUGLAS C1500 CF8M

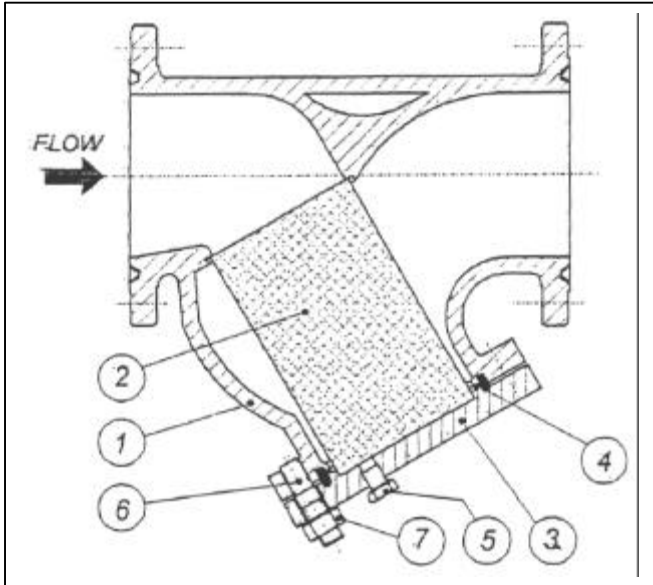

POS.	DESCRIPTION	MATERIALS	SPARES
1	Body	ASTM A351 CF8M	
2	Screen	S.S. 316	X
3	Cover	ASTM A240 316	
4	Gasket RJ	F316	X
5	Drain plug	AISI 316	
6	Studs	ASTM A193 B8	
7	Nuts	ASTM A194 Gr.8	

OTHER MATERIALS ON REQUEST

Size (inches)	2"	3"	4"	6"	8"
<b>SRTJ</b>	371	473	549	711.5	842
<b>SRF</b>	368	470	546	705	832
<b>S</b>	368	470	546	705	832
<b>H</b>	250	325	375	480	620
<b>H1</b>	400	540	600	750	900
<b>Kg</b>	60	100	160	400	600

STANDARD PERFORATIONS 1.5 mm  
SPECIAL PERFORATIONS ON REQUEST. DRAIN PLUG SIZE ¾"  
Dimension : SRF, S, H, H1 are in millimeters ( mm)

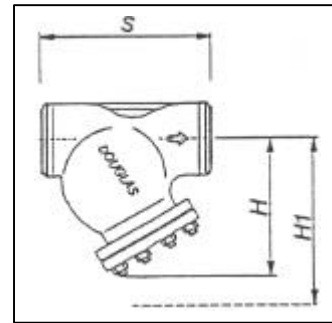
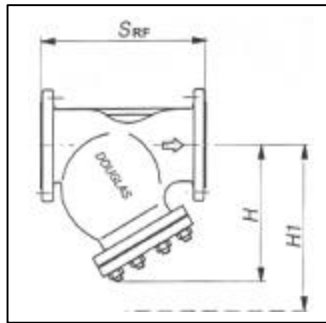
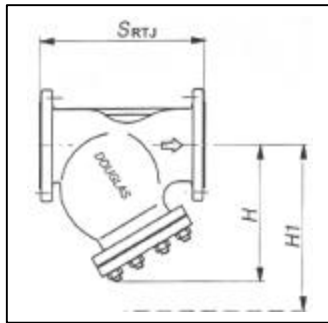

### HOW TO SERVICE

Strainer maintenance should be made at least once year, or whenever the pressure drop is found to be in excess of the normal figures. A quick clean-up system, to made approximately once a month, is to blow-off small impurities trough the drain-plug (5). It is recommended to install a drain valve by a nipple to the drain hole to speed-up this operation. For a complete maintenance follow the points herebelow: **-1-** Be sure that the main line has been shut-off. **-2-** Untighten cover stud bolts (6) and nuts (7) and remove cover (3) and gasket (4). **-3-** Withdraw screen (2) and carefully inspect it for damages. If any hole in the screen is found obstructed, clean it with compressed air and / or any suitable tool. If the screen is broken in any part or out of shape, replace it with a new spare one. **Never reinstall a broken or distorted screen.** **-4-** Carefully clean the inside of the strainer body. **-5-** Fit a new gasket (4). **-6-** Install the new screen or the cleaned one (2). Be sure to center the screen in the upper seat. **-7-** Put in place cover (3). Be sure that drain plug (5) is closed. **-8-** Slowly give pressure to the line, checking for leakages. **9-** Write on the strainer body the date of this maintenance operation.

**How to order: i.e.** C1500 CF8M / 316 F 1.5 2" 900 RTJ

**DOUGLAS ITALIA S.p.A** Località Pradaglie – 29013 CARPANETO PIACENTINO ( PC )

OFFICIAL WEB SITE: [www.douglas-italia.com](http://www.douglas-italia.com)



## STRAINERS

Designed to ANSI B16.34 the strainer bodies are produced with a superior wallthickness for corrosion allowance.

Standard strainers are equipped with screens for the average service of most mediums ( steam, gas, air, oil, chemicals , ect. ).

The large screen open area ensures an efficient filtering action with a low pressure drop.

Filtering area to inlet area ratio is larger than 3 to 1 .  
Screens area manufactured with perforated plate in the materials and with the perforation specified in the relevant tables .

Screens with different perforation ( or wire mesh ) and materials may be manufactured on request.



## INSTALLATION

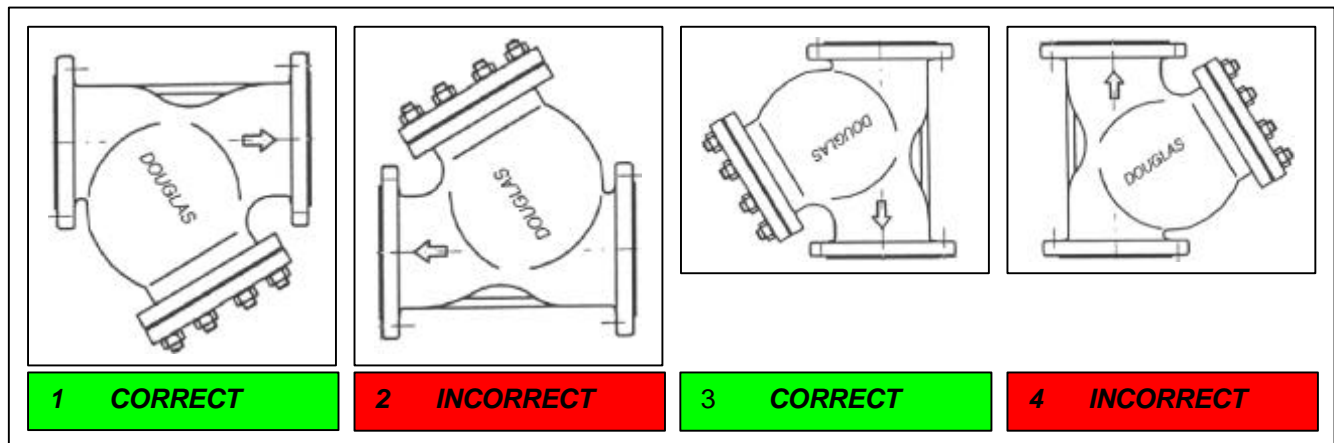

- All strainers should be mounted as close as possible to the valve or machinery which they are being installed to protect. It is important to ensure that the strainer installed with the flow following the same direction as the flow direction arrow cast onto the strainer body.
- For mounting in horizontal or inclined pipelines, ensure that the screen housing is always mounted below the pipeline.
- " Y " – strainers should never be installed in vertical pipelines in the upward flow condition ( see above )

### SIZES

10" – 12" – 14" – 16"

### CONNECTIONS

Buttweld	ANSI B16.25
Flanged	ANSI B 16.5

### LIMITING CONDITIONS ( according to ISO 6552 )

According to the body rating ( ANSI B16.34 )  
C1500 – ANSI 1500  
OTHER RATINGS ON REQUEST



# CAST STEEL " Y " TYPE PRESSURE SEAL STRAINERS C1500 WCB

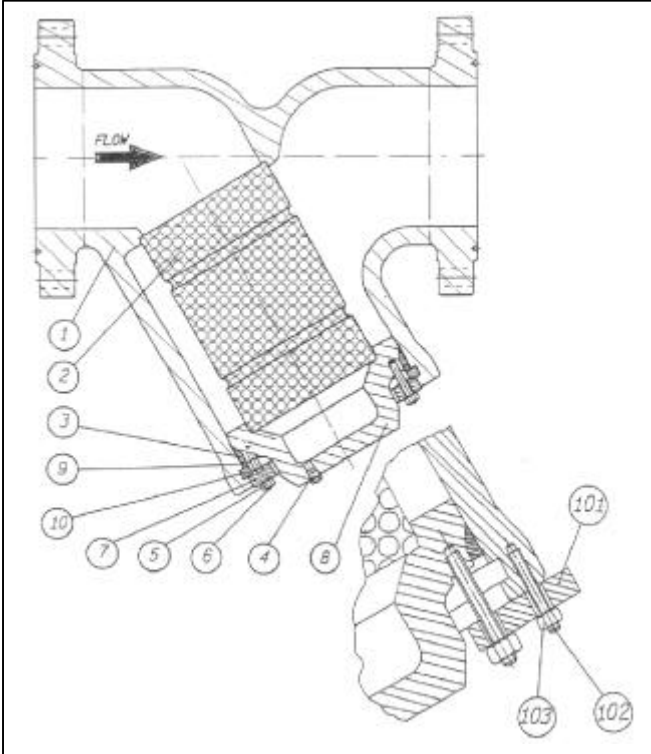

POS.	DESCRIPTION	MATERIALS	SPARES
1	Body	ASTM A216 WCB	
2	Screen	S.S. 304	X
3	Gasket	S.S. 304	X
4	Drain plug	A105	
5	Nuts	ASTM A194 2H	
6	Studs	ASTM A193 B7	
7	Sleeve	ASTM A105	
8	Cover	ASTM A105	
9	Ring	ASTM A182 F6	
10	Retain ring	ASTM A182 F6	

OTHER MATERIALS ON REQUEST

Size (inches)	10"	12"	14"	16"
SRTJ	1000	1146	1276	1407
SRF	991	1130	1257	1384
S	864	991	1067	1194
H	700	800	970	1150
H1	1100	1300	1500	1700
Kg	1200	1500	2320	2750

STANDARD PERFORATIONS 1.5 mm  
SPECIAL PERFORATIONS ON REQUEST. DRAIN PLUG SIZE ¾"  
Dimension : SRF , S , H , H1 are in millimeters ( mm)

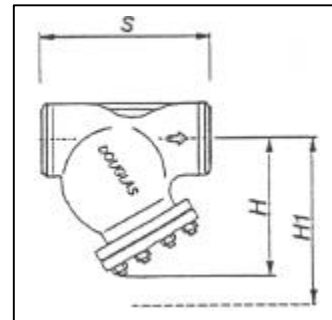
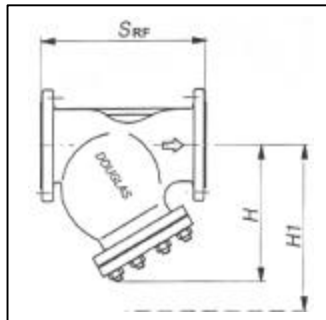
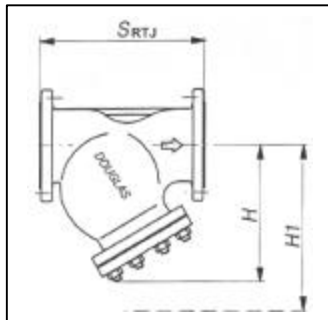

## HOW TO SERVICE

Strainer maintenance should be made at least once year, or whenever the pressure drop is found to be in excess of the normal figures. A quick clean-up system, to made approximately once a month, is to blow-off small impurities trough the drain-plug on cover (4). This operation is faster if a drain valve is installed. For a complete maintenance follow the points herebelow: -1- Be sure that the main line has been shut-off. -2- Untighten nuts (5) remove sleeve (7) and studs (6). -3- Remove retain ring (10) -4- Reinstall the studs (6) to the cover and install studs (102) into threaded holes drilled on the screen casing end. Install four shims (101) with nuts (5 and 103) as per enclosed drawing. -5- Tighten the nuts (5) driving the cover (8) against the shims (101). This will also extract the gasket (3) from its seat and them until the gasket (3) is completely extracted from its seat and the cover (8) can be withdraw from the body. -6- Withdraw screen (2) and carefully inspect it for damages. If any hole in the screen is found obstructed, clean it with compressed air and/or any suitable tool. If the screen is broken in any part or out of shape, replace it with a new spare one. **Never reinstall a broken or distorted screen.** -7- Carefully clean the inside of the strainer body. -8- Install the new screen or the old cleaned one (2). Be sure the center the screen in the upper seat. -9- Install the cover (8) without the studs (6) making sure the screen (2) fits correctly in the cover seat. Check that the cover (8) is fully inserted in the body to allow the installation of the retain ring (10). -10- Install a new gasket (3) and the spacer ring (9). -11- Install retaining ring (10) in their recess in the body, making sure that the holes are visible. -12- Place the sleeve (7) in contact with its seat on the body (1). -13- Slowly cross-tighten the nuts (5) taking care that the cover (8) is kept in axis with the body. This is easily checked watching the gap between the sleeve (7) hole and cover's (8) hub. -14- Slowly give pressure to the line, checking for leakages. -15- Write on the strainer body or tag the date of this maintenance operation.

**How to order: i.e.** C1500 WCB / 304 F 1.5 16" 900 RTJ

**DOUGLAS ITALIA S.p.A** Località Pradaglie – 29013 CARPANETO PIACENTINO ( PC )

OFFICIAL WEB SITE: [www.douglas-italia.com](http://www.douglas-italia.com)

## STRAINERS

Designed to ANSI B16.34 the strainer bodies are produced with a superior wallthickness for corrosion allowance.

Standard strainers are equipped with screens for the average service of most mediums ( steam, gas, air, oil, chemicals , ect. ).

The large screen open area ensures an efficient filtering action with a low pressure drop.

Filtering area to inlet area ratio is larger than 3 to 1 .  
Screens area manufactured with perforated plate in the materials and with the perforation specified in the relevant tables .

Screens with different perforation ( or wire mesh ) and materials may be manufactured on request.



## INSTALLATION

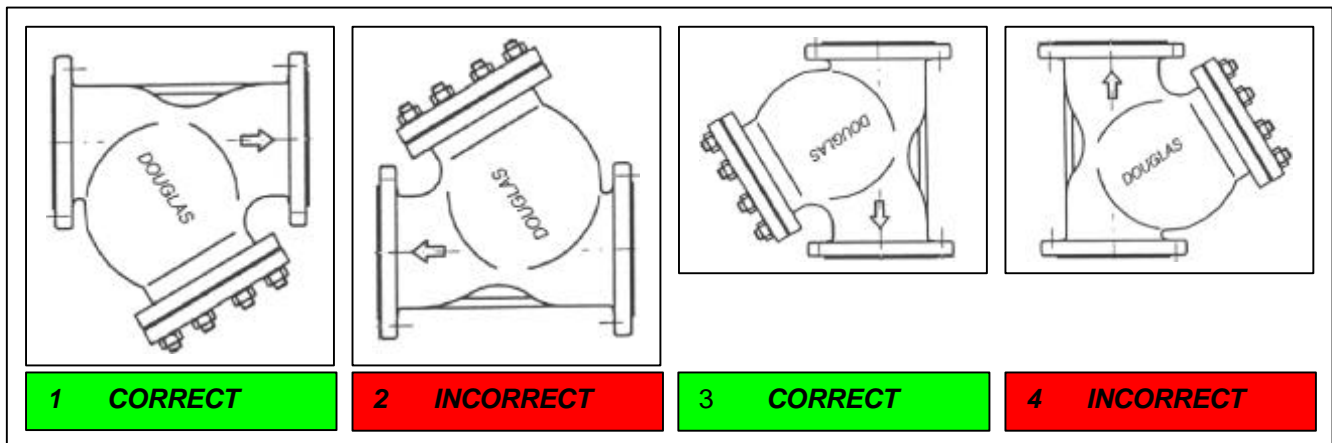

- All strainers should be mounted as close as possible to the valve or machinery which they are being installed to protect. It is important to ensure that the strainer installed with the flow following the same direction as the flow direction arrow cast onto the strainer body.
- For mounting in horizontal or inclined pipelines, ensure that the screen housing is always mounted below the pipeline.
- " Y " – strainers should never be installed in vertical pipelines in the upward flow condition ( see above )

### SIZES

10" – 12" – 14" – 16"

### CONNECTIONS

Buttweld	ANSI B16.25
Flanged	ANSI B 16.5

### LIMITING CONDITIONS ( according to ISO 6552 )

According to the body rating ( ANSI B16.34 )  
C1500 – ANSI 1500  
OTHER RATINGS ON REQUEST

# CAST STEEL " Y " TYPE PRESSURE SEAL STRAINERS C1500 CF8M

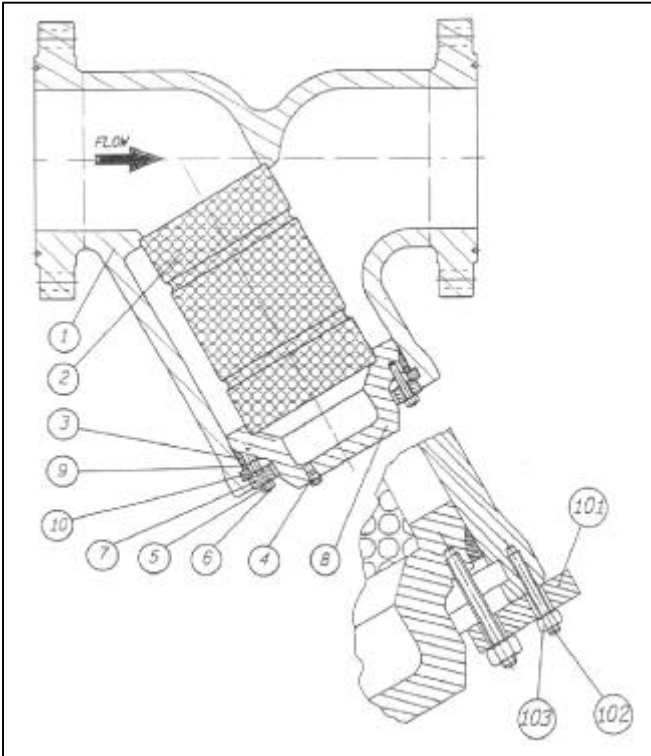

POS.	DESCRIPTION	MATERIALS	SPARES
1	Body	ASTM A351 CF8M	
2	Screen	S.S. 316	X
3	Gasket	A182 F316	X
4	Drain plug	S.S. 316	
5	Nuts	A194 Gr.8	
6	Studs	A193 B8	
7	Sleeve	A182 F316	
8	Cover	A182 F316	
9	Ring	A182 F6	
10	Retain ring	A182 F6	

OTHER MATERIALS ON REQUEST

Size (inches)	10"	12"	14"	16"
SRTJ	1000	1146	1276	1407
SRF	991	1130	1257	1384
S	864	991	1067	1194
H	700	800	970	1150
H1	1100	1300	1500	1700
Kg	1200	1500	2320	2750

STANDARD PERFORATIONS 1.5 mm  
SPECIAL PERFORATIONS ON REQUEST. DRAIN PLUG SIZE ¾"  
Dimension : SRF , S , H , H1 are in millimeters ( mm)

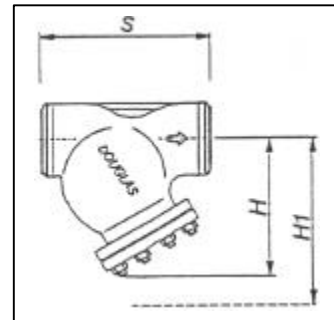
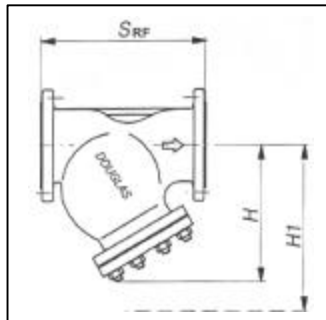
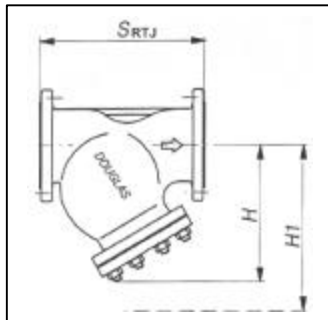

## HOW TO SERVICE

Strainer maintenance should be made at least once year, or whenever the pressure drop is found to be in excess of the normal figures. A quick clean-up system, to made approximately once a month, is to blow-off small impurities trough the drain-plug on cover (4). This operation is faster if a drain valve is installed. For a complete maintenance follow the points herebelow: -1- Be sure that the main line has been shut-off. -2- Untighten nuts (5) remove sleeve (7) and studs (6). -3- Remove retain ring (10) -4- Reinstall the studs (6) to the cover and install studs (102) into threaded holes drilled on the screen casing end. Install four shims (101) with nuts (5 and 103) as per enclosed drawing. -5- Tighten the nuts (5) driving the cover (8) against the shims (101). This will also extract the gasket (3) from its seat and them until the gasket (3) is completely extracted from its seat and the cover (8) can be withdraw from the body. -6- Withdraw screen (2) and carefully inspect it for damages. If any hole in the screen is found obstructed, clean it with compressed air and/or any suitable tool. If the screen is broken in any part or out of shape, replace it with a new spare one. **Never reinstall a broken or distorted screen.** -7- Carefully clean the inside of the strainer body. -8- Install the new screen or the old cleaned one (2). Be sure the center the screen in the upper seat. -9- Install the cover (8) without the studs (6) making sure the screen (2) fits correctly in the cover seat. Check that the cover (8) is fully inserted in the body to allow the installation of the retain ring (10). -10- Install a new gasket (3) and the spacer ring (9). -11- Install retaining ring (10) in their recess in the body, making sure that the holes are visible. -12- Place the sleeve (7) in contact with its seat on the body (1). -13- Slowly cross-tighten the nuts (5) taking care that the cover (8) is kept in axis with the body. This is easily checked watching the gap between the sleeve (7) hole and cover's (8) hub. -14- Slowly give pressure to the line, checking for leakages. -15- Write on the strainer body or tag the date of this maintenance operation.

**How to order: i.e.** C1500 CF8M / 316 F 1.5 16" 900 RTJ

**DOUGLAS ITALIA S.p.A** Località Pradaglie – 29013 CARPANETO PIACENTINO ( PC )

OFFICIAL WEB SITE: [www.douglas-italia.com](http://www.douglas-italia.com)

RATING: DIN PN16  
 MAX.PRESSURE: 16 bar  
 MAX.TEMPERATURE:180°C

FILTER 0,5 mm  
 CONNECTION:  
 SCREWD, BSP, (NPT ON REQUEST)

POS.	DESCRIPTION	MATERIALS	SPARES
1	Body	BRONZE B62	
2	Screen	S.S.	
3	Plug	BRONZE B62	
4	Gasket	GRAPHITE	
5	Drain plug	BRONZE B62	

Filter 40 Mesh  
 OTHER MATERIALS ON REQUEST

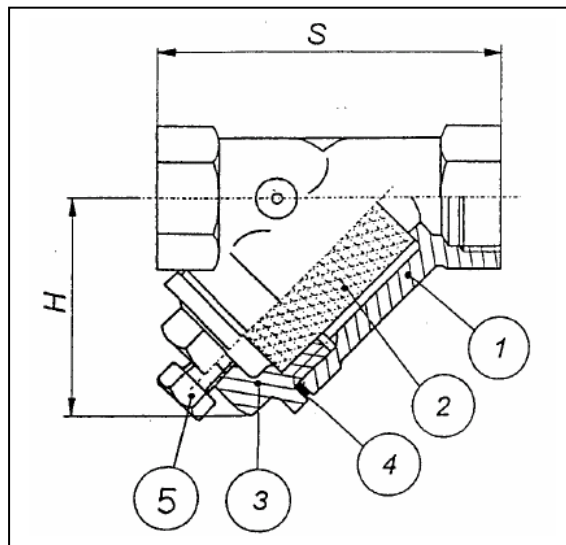

Size (inches)	DRAIN PLUG	S (mm)	H (mm)	Weight (Kg)
3/8"	1/4"	55	40	0.19
1/2"	1/4"	59	44	0.24
3/4"	1/4"	69	50	0.35
1"	1/4"	82	60	0.48
1.1/4"	1/4"	98	73	0.83
1.1/2"	1/4"	109	80	0.94
2"	1/2"	131	98	1.5
2.1/2"	1/2"	151	115	2.35
3"	1/2"	172	130	3.7
4"	1/2"	219	170	6.65

### HOW TO SERVICE

Strainer maintenance should be made at least once year, or whenever the pressure drop is found to be in excess of the normal figures. A quick clean-up system, to made approximately once a month, is to blow-off small impurities through the drain-plug (5). It is recommended to install a drain valve by a nipple to the drain hole to speed-up this operation. For a complete maintenance follow the points herebelow: **-1-** Be sure that the main line has been shut-off. **-2-** Remove cover (3) and gasket (4). **-3-** Withdraw screen (2) and carefully inspect it for damages. If any hole in the screen is found obstructed, clean it with compressed air and / or any suitable tool. If the screen is broken in any part or out of shape, replace it with a new spare one. **Never reinstall a broken or distorted screen.** **-4-** Carefully clean the inside of the strainer body. **-5-** Fit a new gasket (4). **-6-** Install the new screen or the cleaned one (2). Be sure to center the screen in the upper seat. **-7-** Put in place cover (3). Be sure that drain plug (5) is closed. **-8-** Slowly give pressure to the line, checking for leakages. **-9-** Write on the strainer body the date of this maintenance operation.

MODEL & CONNECTIONS				CLIENT REF.	
MODEL	SIZE	CONNECTIONS	DOUGLAS ITEM	ITEM No.:	TAG.No.:
DOUGLAS REF					
CLIENT					
CLIENT P.O. No.					
<b>DOUGLAS ITALIA S.p.a.</b> Loc. Pradaglie Carpaneto (PC) ITALIA				Rev.: 0	Dwg. N. 4B091147
Douglas Italia reserves the right to carry-out any necessary modification without prior notice				Date: 09/02/04	Pag. : 2/2

# *TEMPORARY*

*FT 1*

*FT 2*

*FT 3*

**GO BACK**



## STRAINERS

Conical type temporary strainers are designed for the efficient removal of solids in new pipeline start up service.

They are compact and rugged and can be installed either vertically or horizontally.

They can be manufactured using any kind of wire mesh or perforated plate, in carbon and stainless steel or exotic alloys.

Given dimensions are for reference purpose only. Strainers may be manufactured to any customer's standard.

Strainers are designed to be installed between ANSI B16.5 flanges and meet FF, RF and RTJ facings.

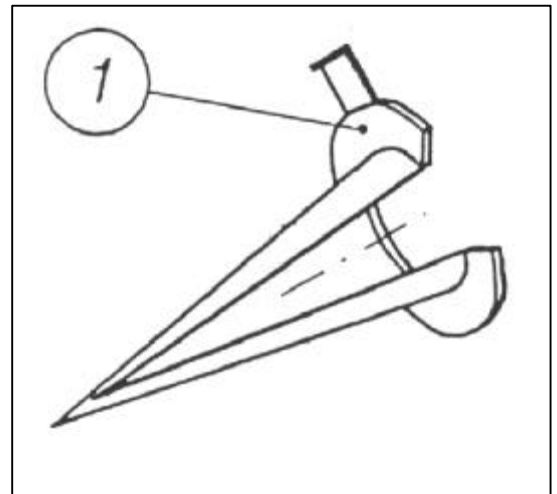
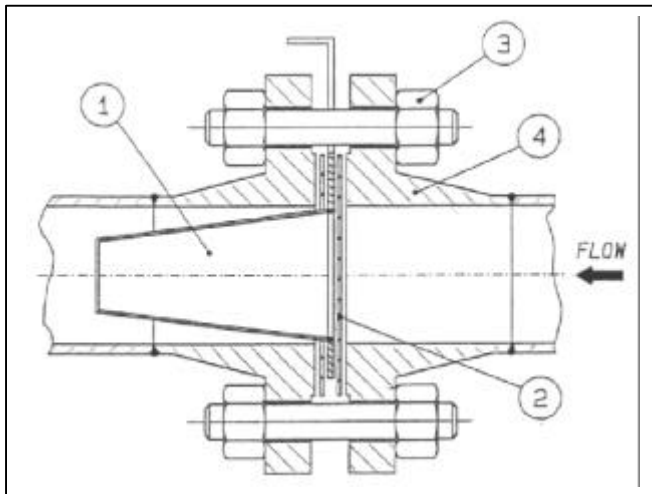

### ASSEMBLY INSTRUCTION

- 1) Insert the strainer between the two flanges ( 4 )
- 2) Make sure the two gasket are fitted on both sides
- 3) Tighten bolts ( 3 ) keeping the strainer ( 1 ) + gaskets ( 2 ) in the correct position

### MAINTENANCE INSTRUCTIONS

- 1) Unscrew bolts ( 3 )
- 2) Remove the strainer ( 1 ) and clean or replace it
- 3) When re-assembling use new gaskets

### SIZES

1½" - 2" - 3" - 4" - 6" - 8" - 10" - 12" - 14" - 16" - 18" - 20" - 24"

## CONICAL TYPE TEMPORARY STRAINERS DOUGLAS FT1

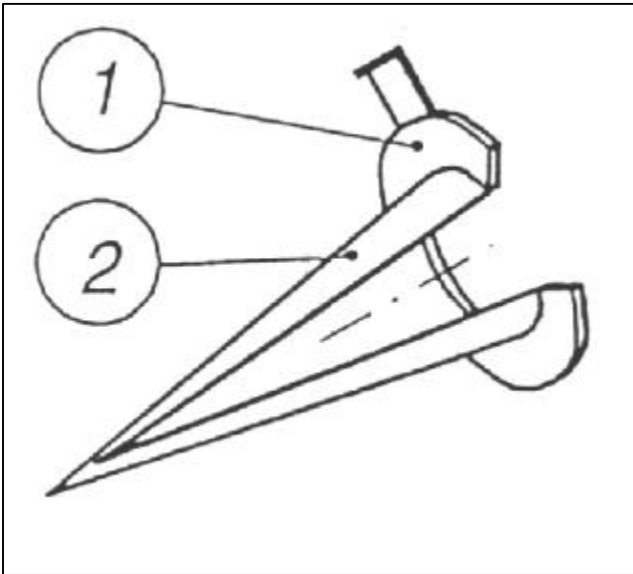

POS.	DESCRIPTION	MATERIALS	SPARES
1	Ring	CARBON STEEL	
2	Perforated plate	ASTM A240 304	
OTHER MATERIALS AND DIMENSIONS ON REQUEST			

Size (inches)	1½"	2"	3"	4"	6"	8"	10"	12"	14"	16"	18"	20"	24"
<b>D</b>	73	92	127	157	216	270	324	381	412	470	534	584	692
<b>H</b>	60	80	120	150	230	300	350	400	450	500	550	600	650
<b>L</b>	70	70	70	80	100	100	110	110	120	130	130	140	150
<b>C</b>	20	20	20	20	20	20	20	20	20	20	20	20	20
<b>S</b>	3	3	3	3	5	5	5	5	5	7	7	7	7
<b>A</b>	33	48	75	100	150	200	250	300	332	383	434	485	587
<b>B</b>	20	26	44	60	89	118	149	175	194	224	250	285	300

Dimensions : D , H , L , C , S , A , B are in millimeters ( mm )  
OTHER SIZES ON REQUEST

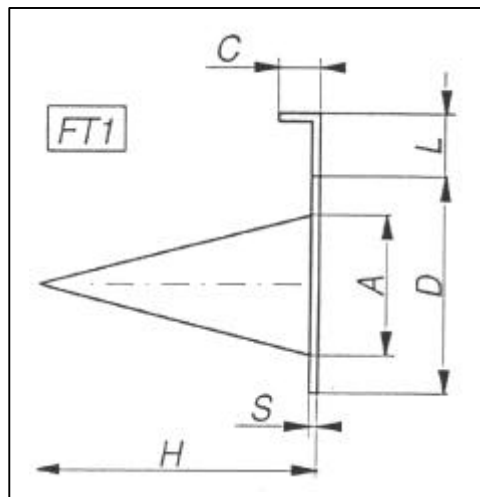

**How to order: i.e.** FT1 4" 150# A240 TP304 – PERF. HOLS 3 mm DIA

**DOUGLAS ITALIA S.p.A** Località Pradaglie – 29013 CARPANETO PIACENTINO ( PC )

OFFICIAL WEB SITE: [www.douglas-italia.com](http://www.douglas-italia.com)

## STRAINERS

Conical type temporary strainers are designed for the efficient removal of solids in new pipeline start up service.

They are compact and rugged and can be installed either vertically or horizontally.

They can be manufactured using any kind of wire mesh or perforated plate, in carbon and stainless steel or exotic alloys.

Given dimensions are for reference purpose only. Strainers may be manufactured to any customer's standard.

Strainers are designed to be installed between ANSI B16.5 flanges and meet FF, RF and RTJ facings.

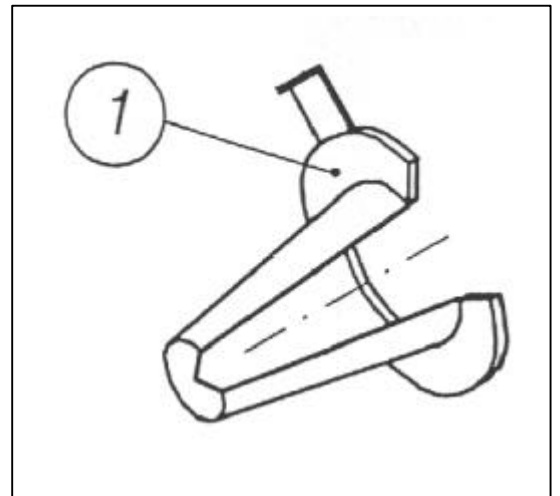
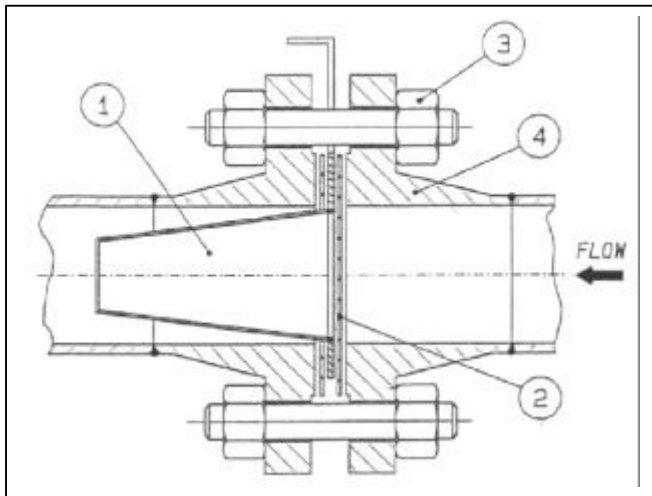
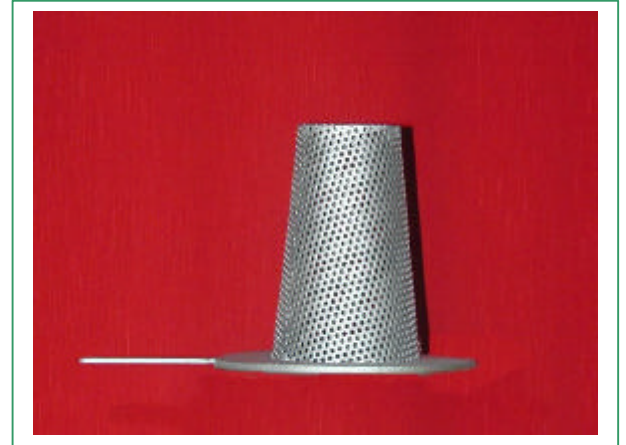

### ASSEMBLY INSTRUCTION

- 1) Insert the strainer between the two flanges ( 4 )
- 2) Make sure the two gasket are fitted on both sides
- 3) Tighten bolts ( 3 ) keeping the strainer ( 1 ) + gaskets ( 2 ) in the correct position

### MAINTENANCE INSTRUCTIONS

- 1) Unscrew bolts ( 3 )
- 2) Remove the strainer ( 1 ) and clean or replace it
- 3) When re-assembling use new gaskets

### SIZES

1½" - 2" - 3" - 4" - 6" - 8" - 10" - 12" - 14" - 16" - 18" - 20" - 24"

## CONICAL TYPE TEMPORARY STRAINERS DOUGLAS FT2

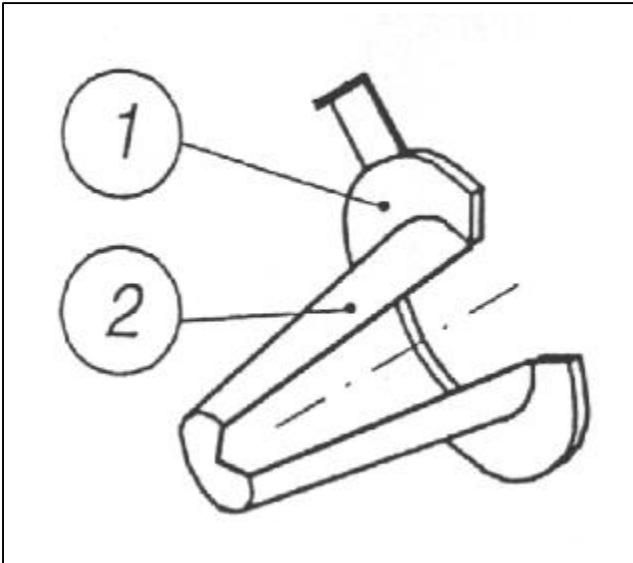

POS.	DESCRIPTION	MATERIALS	SPARES
1	Ring	CARBON STEEL	
2	Perforated plate	ASTM A240 304	
OTHER MATERIALS AND DIMENSIONS ON REQUEST			

Size (inches)	1½"	2"	3"	4"	6"	8"	10"	12"	14"	16"	18"	20"	24"
<b>D</b>	73	92	127	157	216	270	324	381	412	470	534	584	692
<b>H</b>	60	80	120	150	230	300	350	400	450	500	550	600	650
<b>L</b>	70	70	70	80	100	100	110	110	120	130	130	140	150
<b>C</b>	20	20	20	20	20	20	20	20	20	20	20	20	20
<b>S</b>	3	3	3	3	5	5	5	5	5	7	7	7	7
<b>A</b>	33	48	75	100	150	200	250	300	332	383	434	485	587
<b>B</b>	20	26	44	60	89	118	149	175	194	224	250	285	300

Dimensions : D , H , L , C , S , A , B are in millimeters ( mm )  
OTHER SIZES ON REQUEST

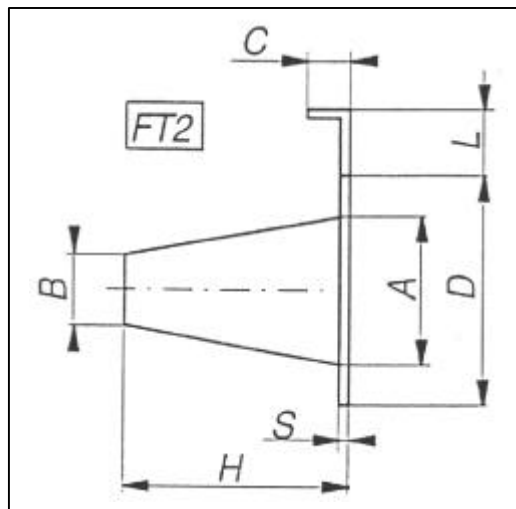

**How to order: i.e.** FT2 4" 150# A240 TP304 – PERF. HOLS 3 mm DIA

**DOUGLAS ITALIA S.p.A** Località Pradaglie – 29013 CARPANETO PIACENTINO ( PC )

OFFICIAL WEB SITE: [www.douglas-italia.com](http://www.douglas-italia.com)

## STRAINERS

Conical type temporary strainers are designed for the efficient removal of solids in new pipeline start up service.

They are compact and rugged and can be installed either vertically or horizontally.

They can be manufactured using any kind of wire mesh or perforated plate, in carbon and stainless steel or exotic alloys.

Given dimensions are for reference purpose only. Strainers may be manufactured to any customer's standard.

Strainers are designed to be installed between ANSI B16.5 flanges and meet FF, RF and RTJ facings.

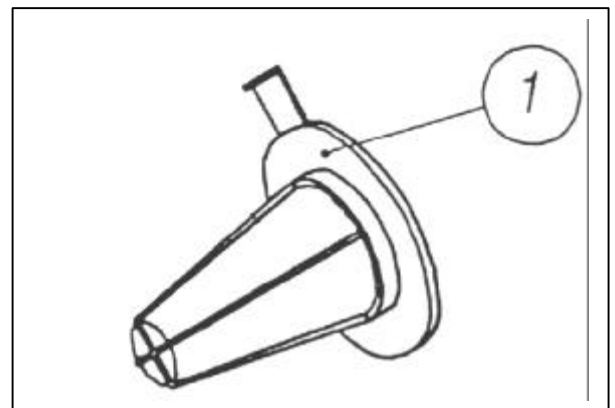
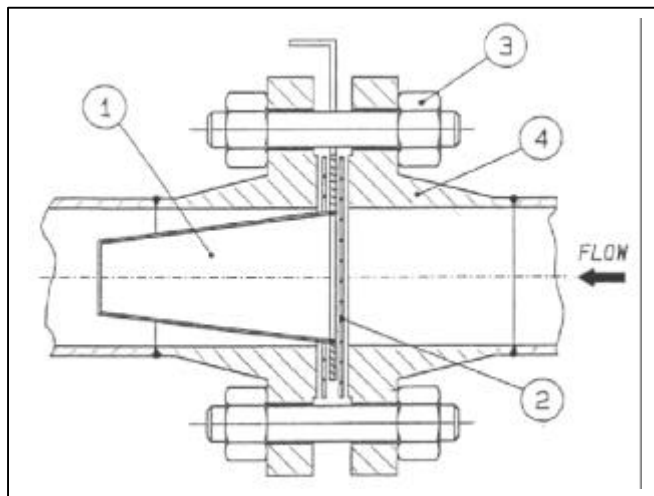

### ASSEMBLY INSTRUCTION

- 1) Insert the strainer between the two flanges ( 4 )
- 2) Make sure the two gasket are fitted on both sides
- 3) Tighten bolts ( 3 ) keeping the strainer ( 1 ) + gaskets ( 2 ) in the correct position

### MAINTENANCE INSTRUCTIONS

- 1) Unscrew bolts ( 3 )
- 2) Remove the strainer ( 1 ) and clean or replace it
- 3) When re-assembling use new gaskets

### SIZES

1½" - 2" - 3" - 4" - 6" - 8" - 10" - 12" - 14" - 16" - 18" - 20" - 24"



## CONICAL TYPE TEMPORARY STRAINERS DOUGLAS FT3

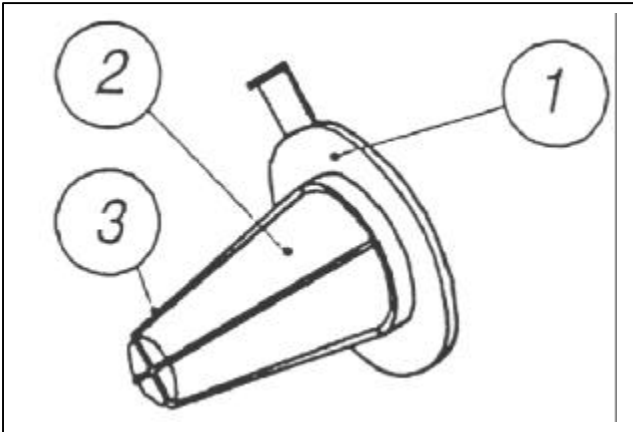

POS.	DESCRIPTION	MATERIALS	SPARES
1	Ring	CARBON STEEL	
2	Wire mesh	S.S. 304	
3	Rods	S.S. 304	
OTHER MATERIALS AND DIMENSIONS ON REQUEST			

Size (inches)	1½"	2"	3"	4"	6"	8"	10"	12"	14"	16"	18"	20"	24"
<b>D</b>	73	92	127	157	216	270	324	381	412	470	534	584	692
<b>H</b>	60	80	120	150	230	300	350	400	450	500	550	600	650
<b>L</b>	70	70	70	80	100	100	110	110	120	130	130	140	150
<b>C</b>	20	20	20	20	20	20	20	20	20	20	20	20	20
<b>S</b>	3	3	3	3	5	5	5	5	5	7	7	7	7
<b>A</b>	33	48	75	100	150	200	250	300	332	383	434	485	587
<b>B</b>	20	26	44	60	89	118	149	175	194	224	250	285	300

Dimensions : D , H , L , C , S , A , B are in millimeters ( mm )  
OTHER SIZES ON REQUEST

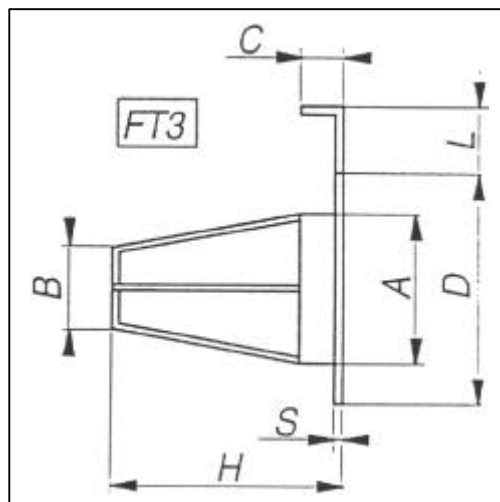

**How to order: i.e.** FT3 4" 150# A240 TP304 – 3 MESH FILTRATION

**DOUGLAS ITALIA S.p.A** Località Pradaglie – 29013 CARPANETO PIACENTINO ( PC )

OFFICIAL WEB SITE: [www.douglas-italia.com](http://www.douglas-italia.com)

# **TEE**

**FS 150**

**FS 300**

**FS 600**

**FS 900**

**GO BACK**

## STRAINERS

Designed to ANSI B16.34 the strainer bodies are produced with a superior wallthickness for corrosion allowance.

Standard strainers are equipped with screens for the average service of most mediums ( steam, gas, air, oil, chemicals , ect. ).

The large screen open area ensures an efficient filtering action with a low pressure drop.

Filtering area to inlet area ratio is larger than 3 to 1 .  
Screens area manufactured with perforated plate in the materials and with the perforation specified in the relevant tables .

Screens with different perforation ( or wire mesh ) and materials may be manufactured on request.



## INSTALLATION

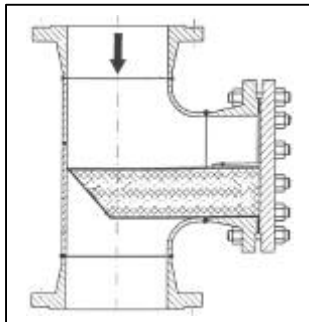

**1 CORRECT**

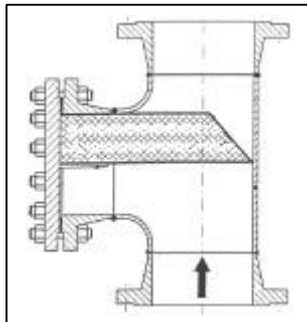

**2 INCORRECT**

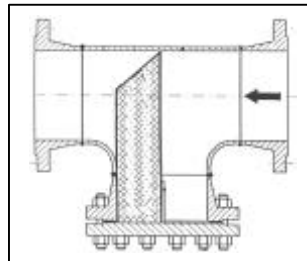

**3 CORRECT**

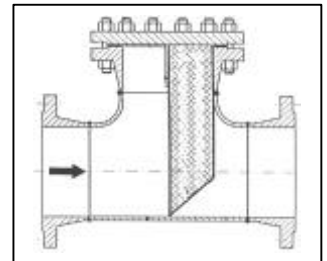

**4 INCORRECT**

- All strainers should be mounted as close as possible to the valve or machinery which they are being installed to protect. It is important to ensure that the strainer installed with the flow following the same direction as the flow direction arrow cast onto the strainer body.
- For mounting in horizontal or inclined pipelines, ensure that the screen housing is always mounted below the pipeline.
- T – strainers should never be installed in vertical pipelines in the upward flow condition. ( see above )

### SIZES

2"–3"–4"–6"–8"–10"–12"–16"–18"–20"–24"

### CONNECTIONS

Buttweld	ANSI B16.25
Flanged	ANSI B16.5

## TEE TYPE STRAINERS DOUGLAS FS150

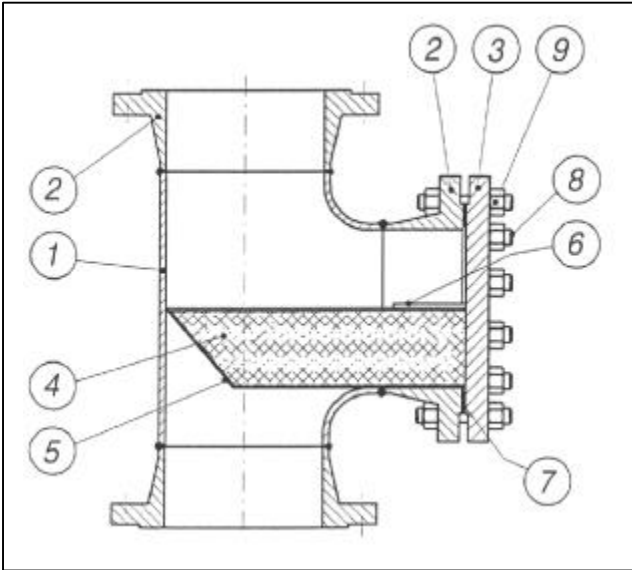

POS.	DESCRIPTION	MATERIALS	SPARES
1	Body	ASTM A234 WPB	
2	Flange	ASTM A105	
3	Blind flange	ASTM A105	
4	Basket	S.S. 304	X
5	Frame	S.S. 304	
6	Guide rods	CARBON STEEL	
7	Gasket	CAF	X
8	Bolts	ASTM A193 B7	
9	Nuts	ASTM A194 2H	
OTHER MATERIALS AND DIMENSIONS ON REQUEST			

Size (inches)	2"	3"	4"	6"	8"	10"	12"	16"	18"	20"	24"
<b>S</b>	127	172	210	286	356	432	508	610	686	762	864
<b>SF</b>	254	312	363	464	560	636	737	864	966	1052	1169
<b>A</b>	148	182	208	260	311	351	403	472	525	571	635
Dimension : SF , S , A are in millimeters ( mm)											

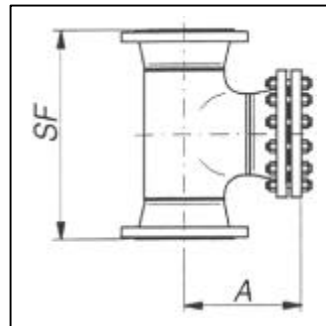
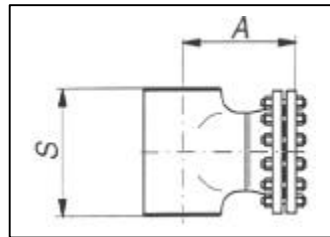

### HOW TO SERVICE

Strainer maintenance should be made at least once year, or whenever the pressure drop is found to be in excess of the normal figures. A quick clean-up system, to made approximately once a month. For a complete maintenance follow the points herebelow: **-1-** Be sure that the main line has been shut-off. **-2-** Untighten cover stud bolts (8) and nuts (9) and remove cover [ blind flange ] (3) and gasket (7). **-3-** Withdraw basket (4) and carefully inspect it for damages. If any hole in the screen is found abstracted, clean it with compressed air and / or any suitable tool. If the basket is broken in any part or out of shape, replace it with a new spare one. **-4-** Carefully clean the inside of the strainer body. **-5-** Fit a new gasket (7). **-6-** Install the new screen or the cleaned one (4). **-7-** Put in place cover (3). **-8-** Slowly give pressure to the line, checking for leakages. **-9-** Write on the strainer body the date of this maintenance operation.

**How to order: i.e.** FS150 WPB – A105 / 304 – 3 MESH – 150 RF

**DOUGLAS ITALIA S.p.A** Località Pradaglie – 29013 CARPANETO PIACENTINO ( PC )

OFFICIAL WEB SITE: [www.douglas-italia.com](http://www.douglas-italia.com)

## STRAINERS

Designed to ANSI B16.34 the strainer bodies are produced with a superior wallthickness for corrosion allowance.

Standard strainers are equipped with screens for the average service of most mediums ( steam, gas, air, oil, chemicals , ect. ).

The large screen open area ensures an efficient filtering action with a low pressure drop.

Filtering area to inlet area ratio is larger than 3 to 1 .  
Screens area manufactured with perforated plate in the materials and with the perforation specified in the relevant tables .

Screens with different perforation ( or wire mesh ) and materials may be manufactured on request.



## INSTALLATION

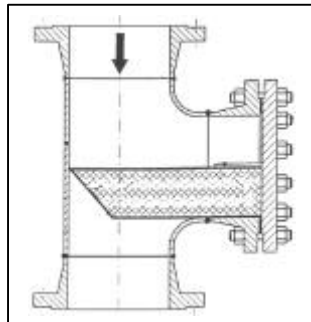

**1 CORRECT**

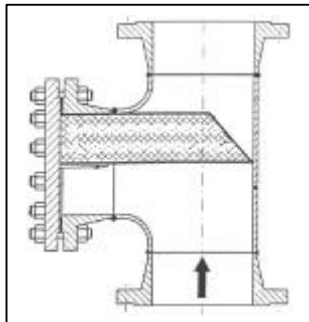

**2 INCORRECT**

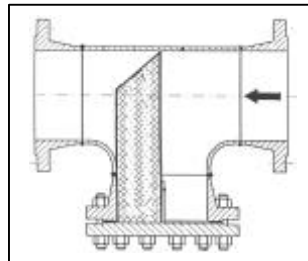

**3 CORRECT**

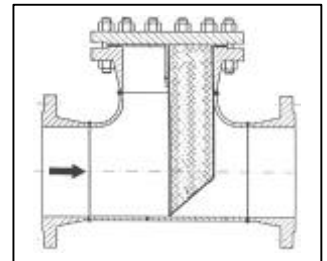

**4 INCORRECT**

- All strainers should be mounted as close as possible to the valve or machinery which they are being installed to protect. It is important to ensure that the strainer installed with the flow following the same direction as the flow direction arrow cast onto the strainer body.
- For mounting in horizontal or inclined pipelines, ensure that the screen housing is always mounted below the pipeline.
- T – strainers should never be installed in vertical pipelines in the upward flow condition. ( see above )

### SIZES

2"–3"–4"–6"–8"–10"–12"–16"–18"–20"–24"

### CONNECTIONS

Buttweld	ANSI B16.25
Flanged	ANSI B16.5



## TEE TYPE STRAINERS DOUGLAS FS300

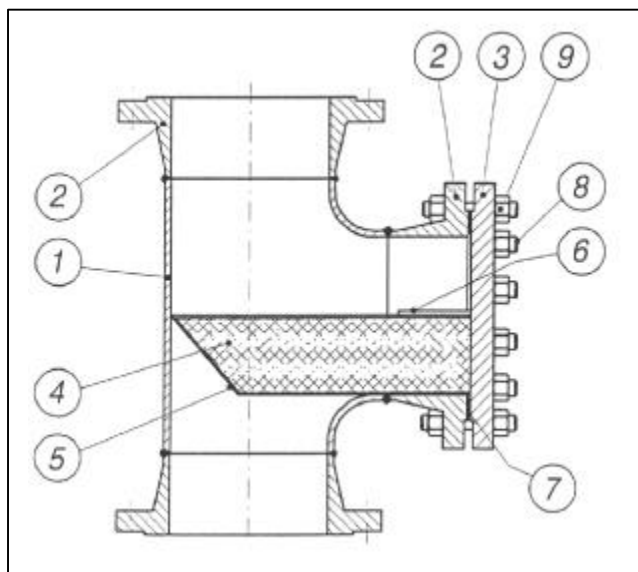

POS.	DESCRIPTION	MATERIALS	SPARES
1	Body	ASTM A234 WPB	
2	Flange	ASTM A105	
3	Blind flange	ASTM A105	
4	Basket	S.S. 304	X
5	Frame	S.S. 304	
6	Guide rods	CARBON STEEL	
7	Gasket	CAF	X
8	Bolts	ASTM A193 B7	
9	Nuts	ASTM A194 2H	

OTHER MATERIALS AND DIMENSIONS ON REQUEST

Size (inches)	2"	3"	4"	6"	8"	10"	12"	16"	18"	20"	24"
<b>S</b>	127	172	210	286	356	432	508	610	686	762	864
<b>SF</b>	268	332	382	483	579	668	769	903	1004	1086	1201
<b>A</b>	158	197	225	281	333	385	438	511	565	609	673

Dimension : SF , S , A are in millimeters ( mm)

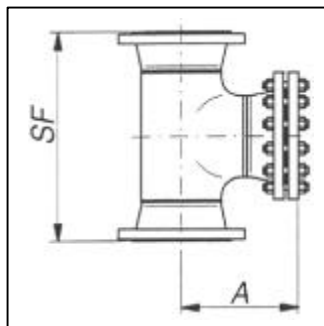
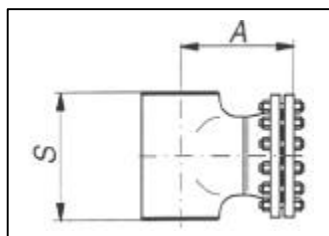

### HOW TO SERVICE

Strainer maintenance should be made at least once year, or whenever the pressure drop is found to be in excess of the normal figures. A quick clean-up system, to made approximately once a month. For a complete maintenance follow the points herebelow: **-1-** Be sure that the main line has been shut-off. **-2-** Untighten cover stud bolts (8) and nuts (9) and remove cover [ blind flange ] (3) and gasket (7). **-3-** Withdraw basket (4) and carefully inspect it for damages. If any hole in the screen is found abstracted, clean it with compressed air and / or any suitable tool. If the basket is broken in any part or out of shape, replace it with a new spare one. **-4-** Carefully clean the inside of the strainer body. **-5-** Fit a new gasket (7). **-6-** Install the new screen or the cleaned one (4). **-7-** Put in place cover (3). **-8-** Slowly give pressure to the line, checking for leakages. **-9-** Write on the strainer body the date of this maintenance operation.

**How to order: i.e.** FS300 WPB – A105 / 304 – 3 MESH – 300 RF

**DOUGLAS ITALIA S.p.A** Località Pradaglie – 29013 CARPANETO PIACENTINO ( PC )

OFFICIAL WEB SITE: [www.douglas-italia.com](http://www.douglas-italia.com)

**STRAINERS**

Designed to ANSI B16.34 the strainer bodies are produced with a superior wallthickness for corrosion allowance.

Standard strainers are equipped with screens for the average service of most mediums ( steam, gas, air, oil, chemicals , ect. ).

The large screen open area ensures an efficient filtering action with a low pressure drop.

Filtering area to inlet area ratio is larger than 3 to 1 .  
Screens area manufactured with perforated plate in the materials and with the perforation specified in the relevant tables .

Screens with different perforation ( or wire mesh ) and materials may be manufactured on request.

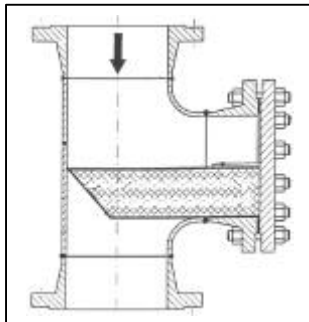
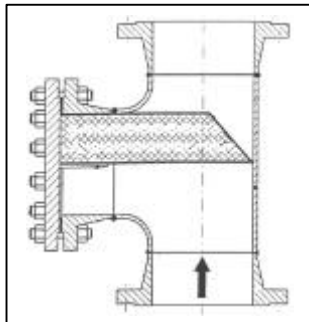
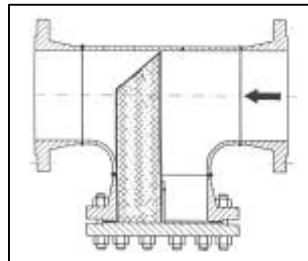
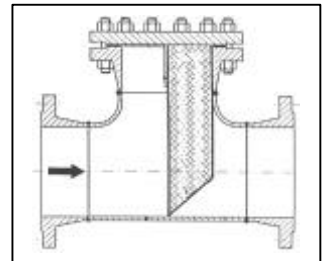
**INSTALLATION**

**1 CORRECT**

**2 INCORRECT**

**3 CORRECT**

**4 INCORRECT**

- All strainers should be mounted as close as possible to the valve or machinery which they are being installed to protect. It is important to ensure that the strainer installed with the flow following the same direction as the flow direction arrow cast onto the strainer body.
- For mounting in horizontal or inclined pipelines, ensure that the screen housing is always mounted below the pipeline.
- T – strainers should never be installed in vertical pipelines in the upward flow condition. ( see above )

**SIZES**

2"–3"–4"–6"–8"–10"–12"–16"–18"–20"–24"

**CONNECTIONS**

Buttweld	ANSI B16.25
Flanged	ANSI B16.5

## TEE TYPE STRAINERS DOUGLAS FS600

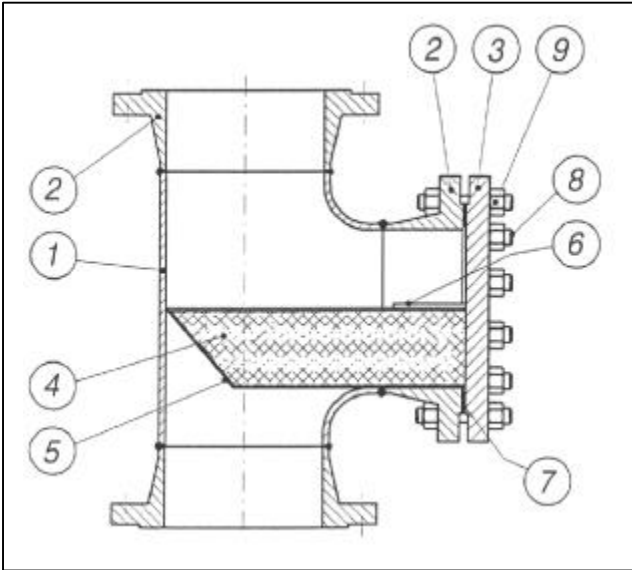

POS.	DESCRIPTION	MATERIALS	SPARES
1	Body	ASTM A234 WPB	
2	Flange	ASTM A105	
3	Blind flange	ASTM A105	
4	Basket	S.S. 304	X
5	Frame	S.S. 304	
6	Guide rods	CARBON STEEL	
7	Gasket	CAF	X
8	Bolts	ASTM A193 B7	
9	Nuts	ASTM A194 2H	

OTHER MATERIALS AND DIMENSIONS ON REQUEST

Size (inches)	2"	3"	4"	6"	8"	10"	12"	16"	18"	20"	24"
<b>S</b>	127	172	210	286	356	432	508	610	686	762	864
<b>SF</b>	286	351	427	535	636	750	833	979	1067	1156	1284
<b>A</b>	177	216	260	324	382	447	492	574	624	676	753

Dimension : SF , S , A are in millimeters ( mm)

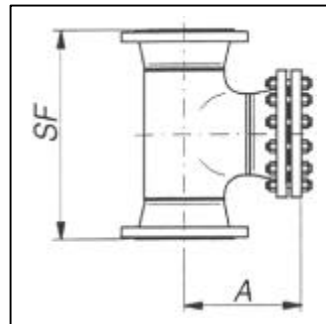
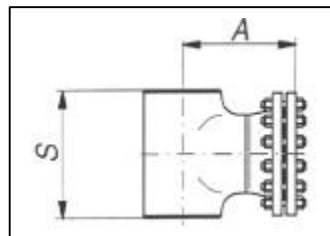

### HOW TO SERVICE

Strainer maintenance should be made at least once year, or whenever the pressure drop is found to be in excess of the normal figures. A quick clean-up system, to made approximately once a month. For a complete maintenance follow the points herebelow: **-1-** Be sure that the main line has been shut-off. **-2-** Untighten cover stud bolts (8) and nuts (9) and remove cover [ blind flange ] (3) and gasket (7). **-3-** Withdraw basket (4) and carefully inspect it for damages. If any hole in the screen is found obstructed, clean it with compressed air and / or any suitable tool. If the basket is broken in any part or out of shape, replace it with a new spare one. **-4-** Carefully clean the inside of the strainer body. **-5-** Fit a new gasket (7). **-6-** Install the new screen or the cleaned one (4). **-7-** Put in place cover (3). **-8-** Slowly give pressure to the line, checking for leakages. **-9-** Write on the strainer body the date of this maintenance operation.

**How to order: i.e.** FS600 WPB – A105 / 304 – 3 MESH – 600 RF

**DOUGLAS ITALIA S.p.A** Località Pradaglie – 29013 CARPANETO PIACENTINO ( PC )

OFFICIAL WEB SITE: [www.douglas-italia.com](http://www.douglas-italia.com)

**STRAINERS**

Designed to ANSI B16.34 the strainer bodies are produced with a superior wallthickness for corrosion allowance.

Standard strainers are equipped with screens for the average service of most mediums ( steam, gas, air, oil, chemicals , ect. ).

The large screen open area ensures an efficient filtering action with a low pressure drop.

Filtering area to inlet area ratio is larger than 3 to 1 .

Screens area manufactured with perforated plate in the materials and with the perforation specified in the relevant tables .

Screens with different perforation ( or wire mesh ) and materials may be manufactured on request.

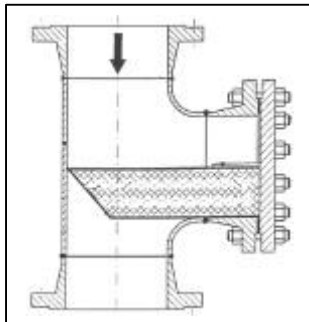
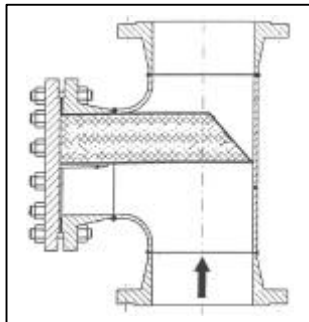
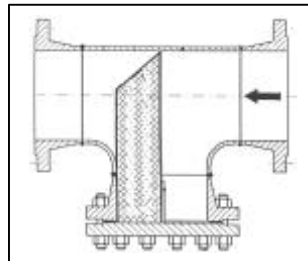
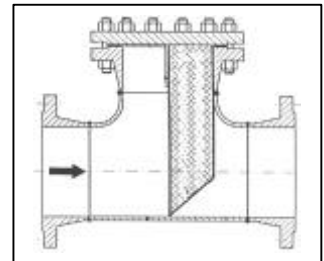
**INSTALLATION**

**1 CORRECT**

**2 INCORRECT**

**3 CORRECT**

**4 INCORRECT**

- All strainers should be mounted as close as possible to the valve or machinery which they are being installed to protect. It is important to ensure that the strainer installed with the flow following the same direction as the flow direction arrow cast onto the strainer body.
- For mounting in horizontal or inclined pipelines, ensure that the screen housing is always mounted below the pipeline.
- T – strainers should never be installed in vertical pipelines in the upward flow condition. ( see above )

**SIZES**

2"–3"–4"–6"–8"–10"–12"–16"–18"–20"–24"

**CONNECTIONS**

Buttweld	ANSI B16.25
Flanged	ANSI B16.5

## TEE TYPE STRAINERS DOUGLAS FS900

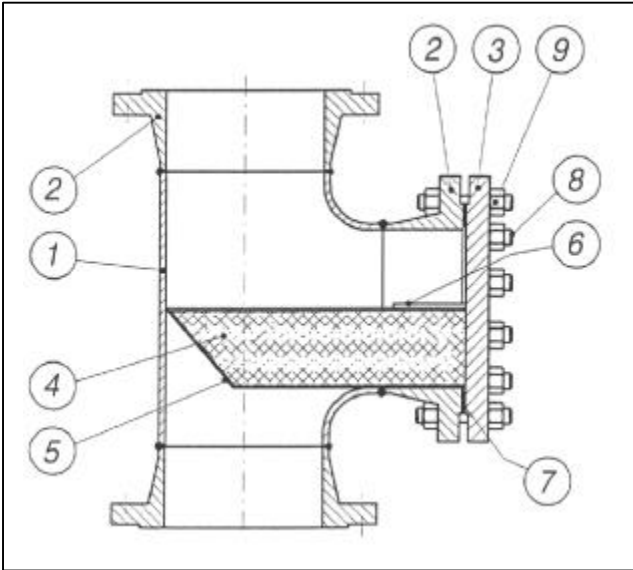

POS.	DESCRIPTION	MATERIALS	SPARES
1	Body	ASTM A234 WPB	
2	Flange	ASTM A105	
3	Blind flange	ASTM A105	
4	Basket	S.S. 304	X
5	Frame	S.S. 304	
6	Guide rods	CARBON STEEL	
7	Gasket	CAF	X
8	Bolts	ASTM A193 B7	
9	Nuts	ASTM A194 2H	
OTHER MATERIALS AND DIMENSIONS ON REQUEST			

Size (inches)	2"	3"	4"	6"	8"	10"	12"	16"	18"	20"	24"
<b>S</b>	127	172	210	286	356	432	508	610	686	762	864
<b>SF</b>	343	389	453	579	694	813	922	1056	1157	1271	1462
<b>A</b>	219	242	279	353	419	485	549	626	689	752	879
Dimension : SF , S , A are in millimeters ( mm)											

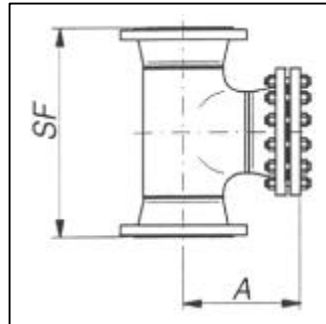
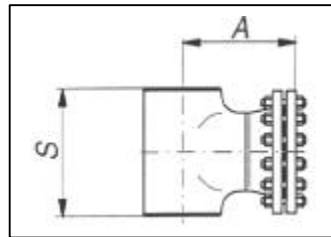

### HOW TO SERVICE

Strainer maintenance should be made at least once year, or whenever the pressure drop is found to be in excess of the normal figures. A quick clean-up system, to made approximately once a month. For a complete maintenance follow the points herebelow: **-1-** Be sure that the main line has been shut-off. **-2-** Untighten cover stud bolts (8) and nuts (9) and remove cover [ blind flange ] (3) and gasket (7). **-3-** Withdraw basket (4) and carefully inspect it for damages. If any hole in the screen is found obstructed, clean it with compressed air and / or any suitable tool. If the basket is broken in any part or out of shape, replace it with a new spare one. **-4-** Carefully clean the inside of the strainer body. **-5-** Fit a new gasket (7). **-6-** Install the new screen or the cleaned one (4). **-7-** Put in place cover (3). **-8-** Slowly give pressure to the line, checking for leakages. **-9-** Write on the strainer body the date of this maintenance operation.

**How to order:** i.e. FS900 WPB – A105 / 304 – 3 MESH – 900 RF

**DOUGLAS ITALIA S.p.A** Località Pradaglie – 29013 CARPANETO PIACENTINO ( PC )

OFFICIAL WEB SITE: [www.douglas-italia.com](http://www.douglas-italia.com)



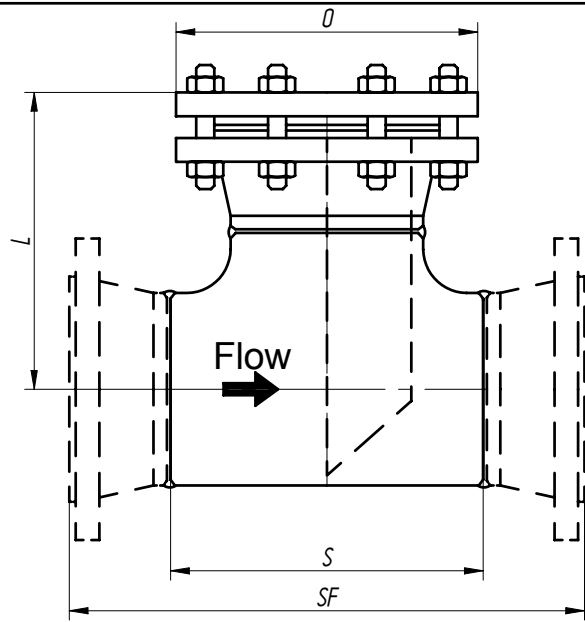

**TEE RUN TYPE STRAINER**

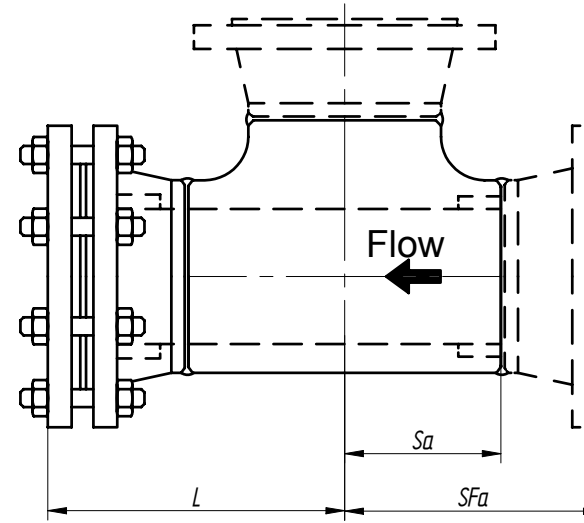
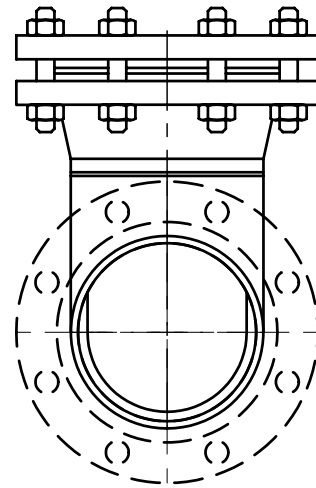

**TEE ANGLE TYPE STRAINER**

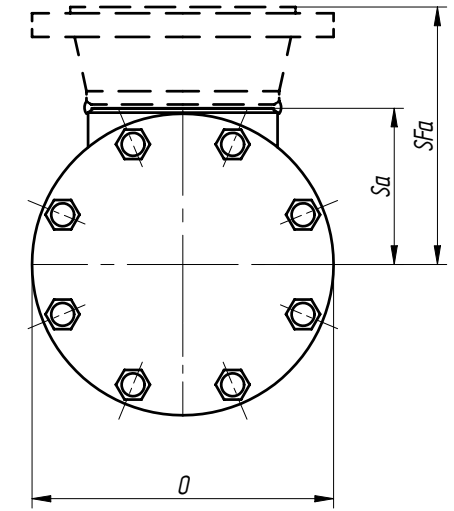

SIZE	S	Sa	SF					Sfa					L					O								
RATING	150	300	600	900	1500	2500	150	300	600	900	1500	2500	150	300	600	900	1500	2500	150	300	600	900	1500	2500		
2"	127	63,5	258	271	290	####	347	398	129	135	145	####	174	199	152	162	181	####	222	260	152	165	165	no	216	235
2 1/2"	152	76,2	296	309	328	####	379	455	148	154	164	####	189	228	174	184	203	####	241	295	178	190	190	no	244	267
3"	171	85,7	315	334	353	391	423	525	158	167	177	196	212	262	186	200	219	244	270	339	190	210	210	241	267	305
4"	210	105	366	385	430	455	474	607	183	193	215	228	237	304	211	228	263	282	301	390	229	254	273	292	311	356
5"	248	124	429	448	493	518	576	722	215	224	247	259	288	361	243	263	301	320	371	463	254	279	330	349	375	419
6"	286	143	467	486	537	582	645	849	234	243	269	291	323	424	263	284	327	357	416	543	279	318	356	381	394	483
8"	356	178	563	582	639	696	798	1007	281	291	320	348	399	504	314	336	386	422	501	641	343	381	419	470	483	552
10"	432	216	639	671	753	817	957	1287	320	335	377	409	478	643	354	387	451	489	597	819	406	444	508	546	584	673
12"	508	254	741	772	836	925	1090	1452	370	386	418	462	545	726	406	441	495	552	679	921	483	521	559	610	673	762
14"	559	279	817	849	906	1001	1173	####	408	424	453	501	586	####	447	482	533	597	730	####	533	584	603	641	749	no
16"	610	305	868	906	982	1058	1249	####	434	453	491	529	624	####	474	514	578	628	781	####	597	648	686	705	826	no
18"	686	343	969	1007	1071	1160	1357	####	485	504	536	580	679	####	528	568	629	692	851	####	635	711	743	787	914	no
20"	762	381	1055	1090	1160	1274	1490	####	528	545	580	637	745	####	574	612	679	756	933	####	698	775	813	857	984	no
24"	864	432	1172	1204	1287	1465	1693	####	586	602	643	732	847	####	638	676	755	882	1060	####	813	914	940	1041	1168	no

-Flange dimensions are according to ANSI B16.5

0	26/09/03	Issue			
Rev. N°	Data / Date	Descrizione / Description	Disegnato/Dwrd.	Controllato/Chkd.	Approvato/App.

**TEE TYPE STRAINER GENERAL DIMENSIONS**



N. Disegno / Dwg. No.  
**31261538**  
Foglio Sheet  
1/1

Disegno di proprietà della DOUGLAS ITALIA. Non può essere copiato, riprodotto, in tutto o in parte, o mostrato a terzi senza autorizzazione. This drawing is property of DOUGLAS ITALIA and all right of use and reproduction are reserved.



# ***SIMPLEX***

***MO 150***

***MO 300***

***GO BACK***

**SIMPLEX STRAINERS**

Douglas Italia fabricated Simplex ( basket ) strainers have been specifically designed to meet all customer requirements including for high pressure applications.

Designed and fabricated to ASME VIII Div.1 as standard but can also be supplied to other pressure vessel codes. I.e. ASME B31.3 etc.

Standard features include low pressure drops at high velocities, stainless steel perforated baskets as standard, vents and drains with the possibility to supply davit lifts, quick open closures, DP gauges.

We are also able to manufacture against customer requests in all types of materials.

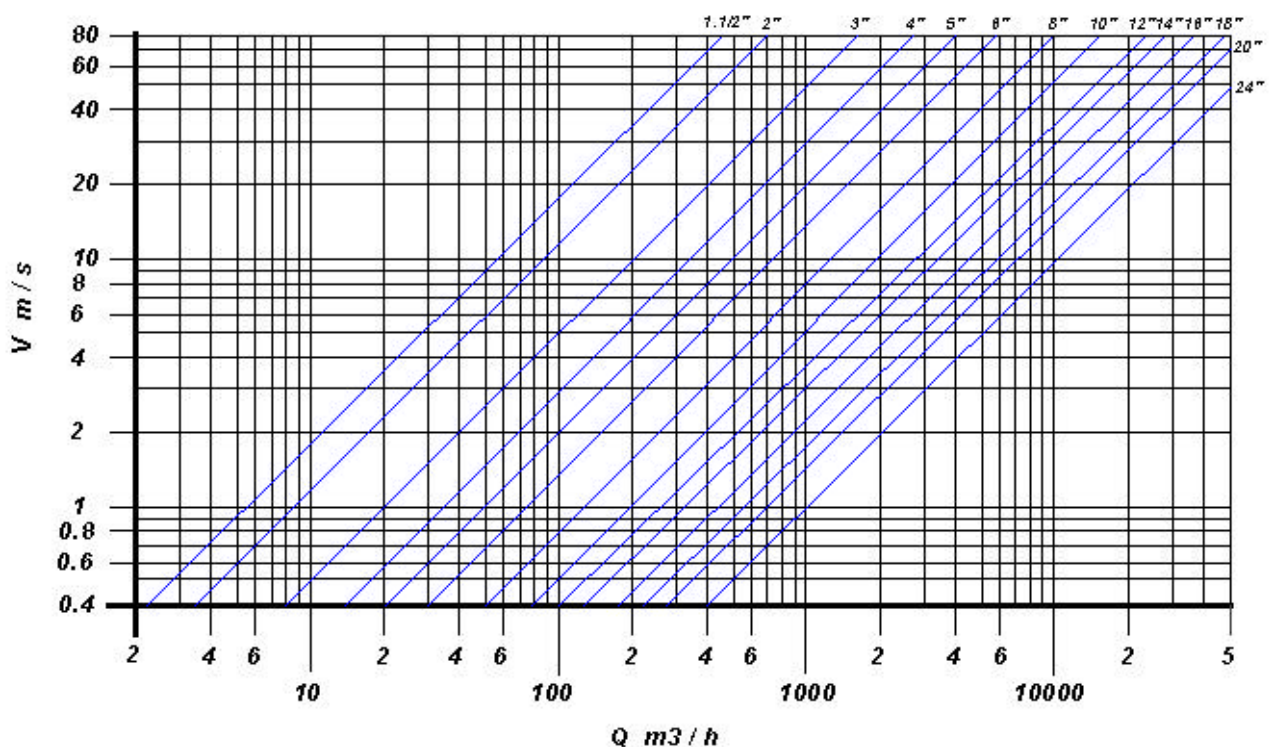

## SIMPLEX FILTERS MO 150

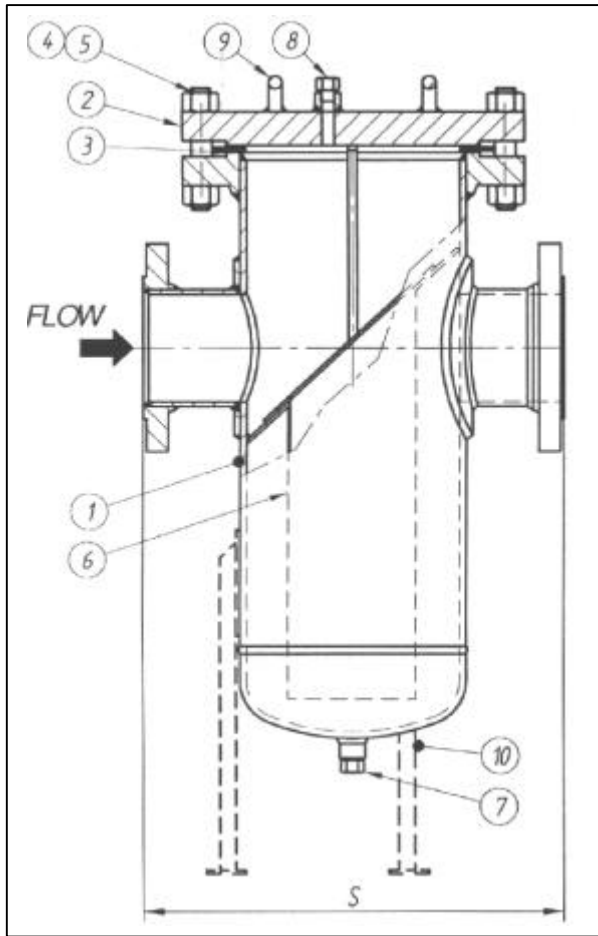

POS.	DESCRIPTION	MATERIALS	NOTE
1	Body	ASTM A106	
2	Cover	ASTM A105	
3	Gasket	316 / GRAPHITE	
4	Studs	ASTM A193 B7	
5	Nuts	ASTM A194 2H	
6	Screen	Stainless steel	
	Perf. Plate	Stainless steel	
	Mesh	Stainless steel	
7	Drain	ASTM A105	Screwed 3/4" NPT
8	Vent	ASTM A105	Screwed 3/4" NPT
9	Lifting eyes	CARBON STEEL	For cover only
10	Legs	CARBON STEEL	

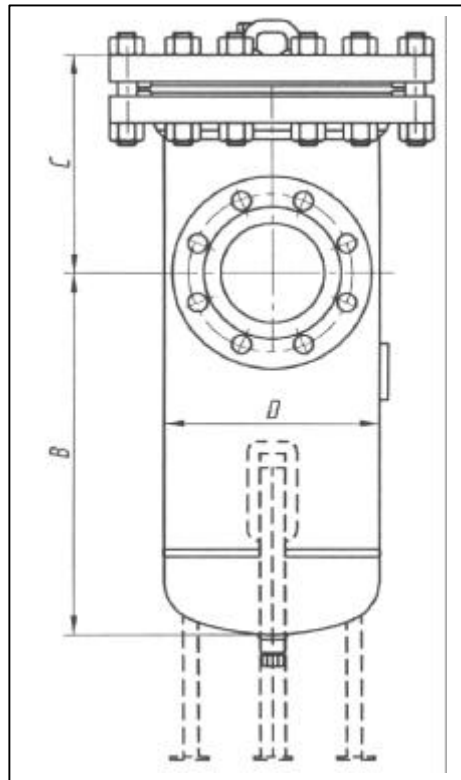

Size (inches)	1 1/2"	2"	3"	4"	5"	6"	8"	10"	12"	14"	16"	18"	20"	24"
S ( mm )	356	356	381	406	406	508	559	813	889	940	1067	1067	1092	1219
B ( mm )	305	305	318	356	381	432	533	635	711	838	914	991	1118	1524
C ( mm )	163	178	203	210	241	241	279	330	368	400	464	464	553	553
D ( mm )	168	168	168	219	273	273	324	406	457	508	610	610	762	762
Kg	40.0	43.1	46.7	77.1	104.3	108.9	154.2	272.2	349.3	440.0	616.9	635.0	870.9	997.9

**NOTES : Inlet / Outlet flanges are according to ANSI B16.5**

**DOUGLAS ITALIA S.p.A** Località Pradaglie – 29013 CARPANETO PIACENTINO ( PC )

OFFICIAL WEB SITE: [www.douglas-italia.com](http://www.douglas-italia.com)

**SIMPLEX STRAINERS**

Douglas Italia fabricated Simplex ( basket ) strainers have been specifically designed to meet all customer requirements including for high pressure applications.

Designed and fabricated to ASME VIII Div.1 as standard but can also be supplied to other pressure vessel codes. I.e. ASME B31.3 etc.

Standard features include low pressure drops at high velocities, stainless steel perforated baskets as standard, vents and drains with the possibility to supply davit lifts, quick open closures, DP gauges.

We are also able to manufacture against customer requests in all types of materials

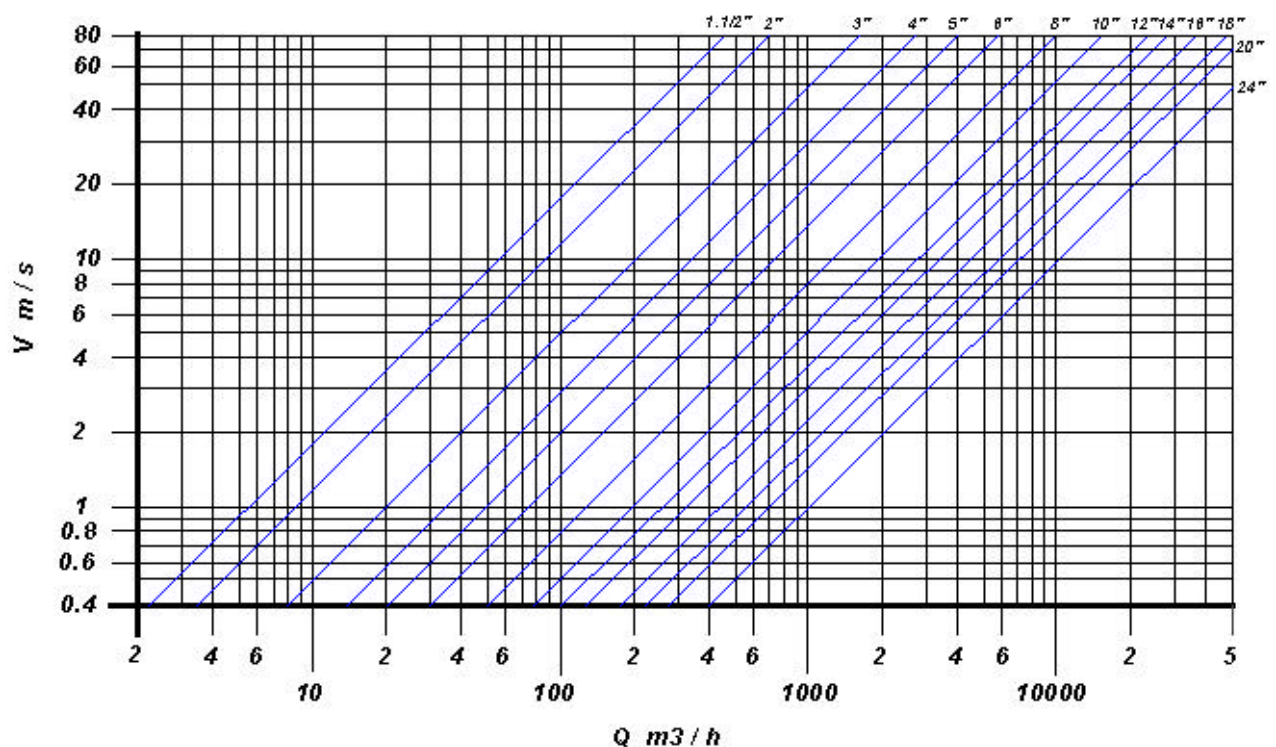



## SIMPLEX FILTERS MO 300

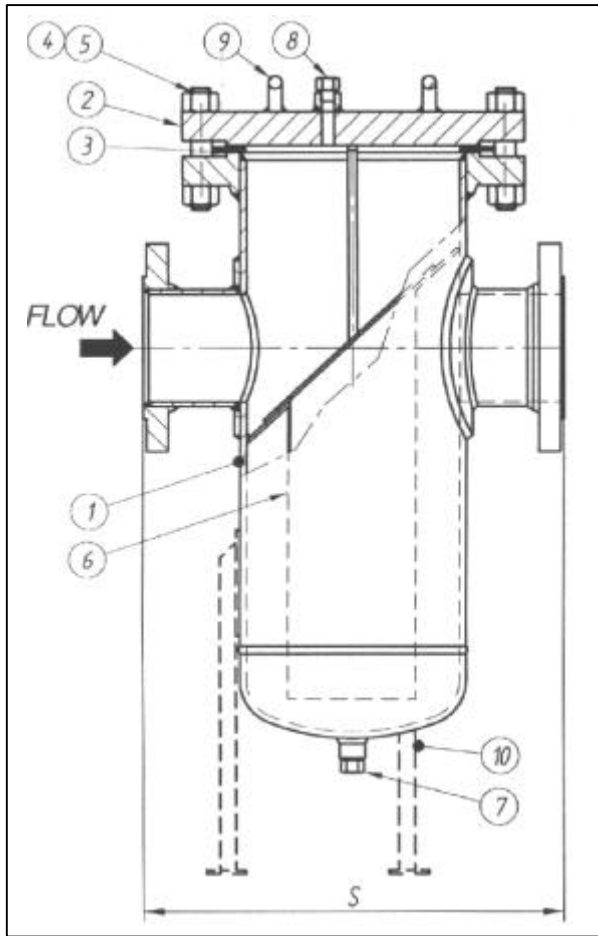

POS.	DESCRIPTION	MATERIALS	NOTE
1	Body	ASTM A106	
2	Cover	ASTM A105	
3	Gasket	316 / GRAPHITE	
4	Studs	ASTM A193 B7	
5	Nuts	ASTM A194 2H	
6	Screen	Stainless steel	
	Perf. Plate	Stainless steel	
	Mesh	Stainless steel	
7	Drain	ASTM A105	Screwed 3/4" NPT
8	Vent	ASTM A105	Screwed 3/4" NPT
9	Lifting eyes	CARBON STEEL	For cover only
10	Legs	CARBON STEEL	

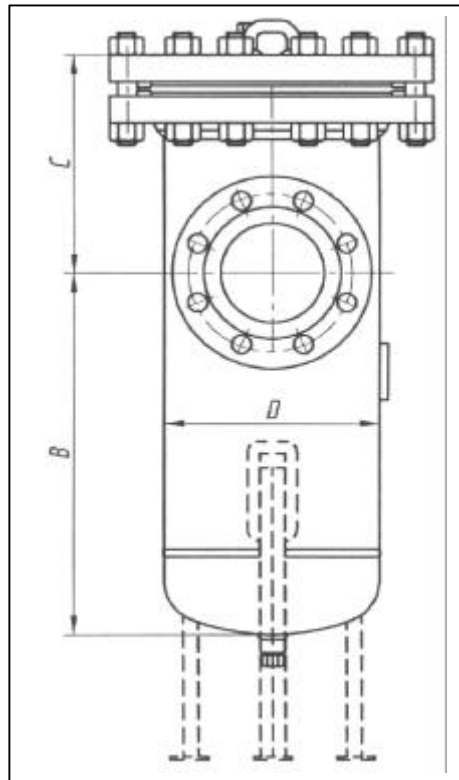

Size (inches)	1 1/2"	2"	3"	4"	5"	6"	8"	10"	12"	14"	16"	18"	20"	24"
S (mm)	356	356	381	406	445	553	584	838	914	965	1092	1092	1130	1264
B (mm)	305	305	318	356	381	432	533	635	711	838	914	991	1118	1524
C (mm)	229	229	229	241	279	279	318	368	406	445	508	508	610	610
D (mm)	168	168	168	219	273	273	324	406	457	508	610	610	762	762
Kg	69.2	72.6	79.4	131.5	181.4	192.8	274.4	464.9	603.3	757.5	1059.1	1115.8	1537.7	1780.4

**NOTES : Inlet / Outlet flanges are according to ANSI B16.5**

**DOUGLAS ITALIA S.p.A** Località Pradaglie – 29013 CARPANETO PIACENTINO ( PC )

OFFICIAL WEB SITE: [www.douglas-italia.com](http://www.douglas-italia.com)

**DUPLEX STRAINERS**

Douglas Italia fabricated Duplex ( basket ) strainers have been specifically designed to meet all customer requirements including for high pressure applications.

Designed and fabricated to ASME VIII Div.1 as standard but can also be supplied to other pressure vessel codes. I.e. ASME B31.3 etc.

Standard features include low pressure drops at high velocities, stainless steel perforated baskets as standard, vents and drains with the possibility to supply davit lifts, quick open closures, DP gauges.

We are also able to manufacture against customer requests in all types of materials.

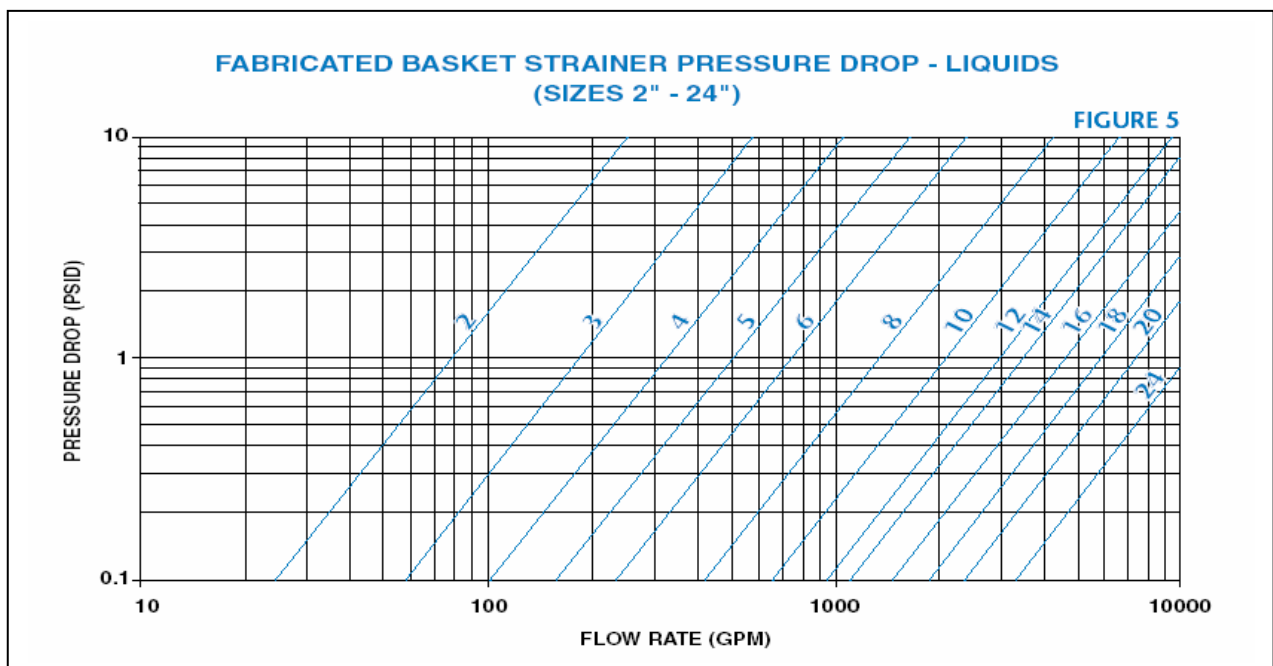

## DUPLIX FILTERS DU 150

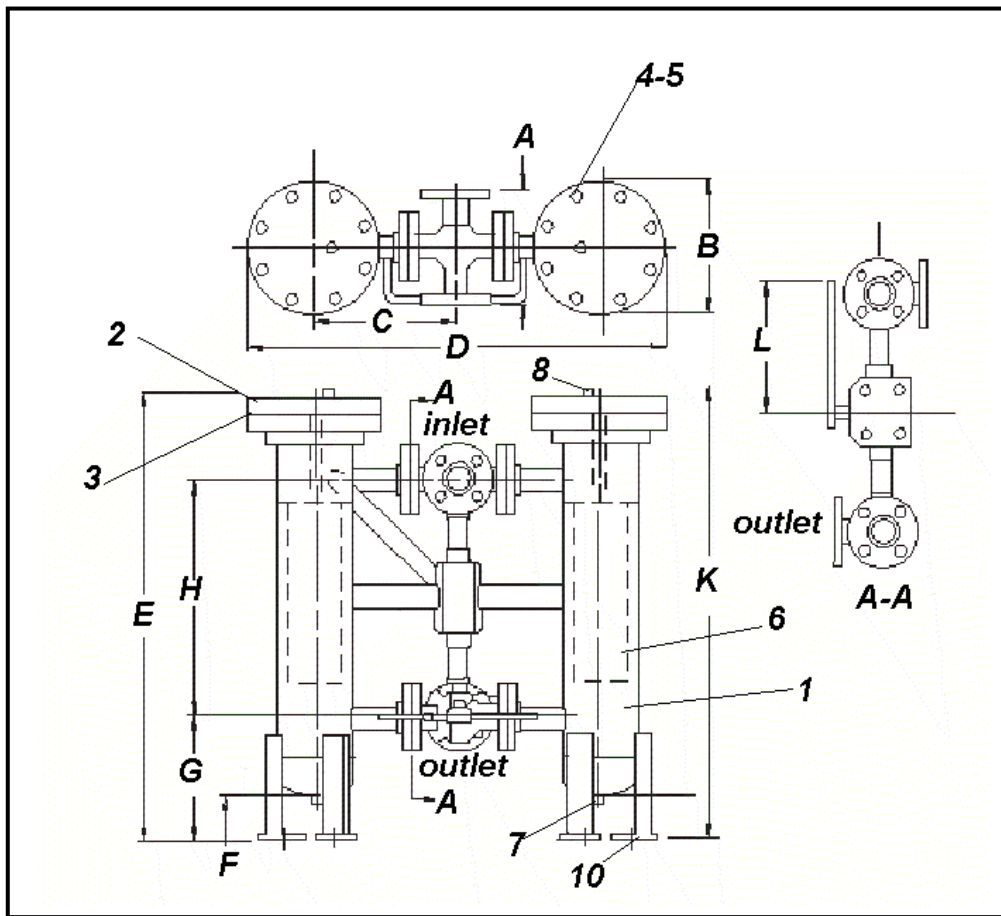

POS.	DESCRIPTION	MATERIALS	NOTE
1	Body	ASTM A106	
2	Cover	ASTM A105	
3	Gasket	316 / GRAPHITE	
4	Studs	ASTM A193 B7	
5	Nuts	ASTM A194 2H	
6	Screen	Stainless steel	
	Perf. Plate	Stainless steel	
	Mesh	Stainless steel	
7	Drain	ASTM A105	Screwed 3/4" NPT
8	Vent	ASTM A105	Screwed 3/4" NPT
9	Lifting eyes	CARBON STEEL	For cover only
10	Legs	CARBON STEEL	

Size (inches)	A	B	C	D	E	F	G	H	K				
1 1/2"	216	279	330	914	965	100	279	159	1524				
2"	220	279	337	925	991	100	279	159	1550				
3"	260	279	356	965	1105	100	279	159	1700				
4"	330	343	438	1232	1197	100	305	190	1900				
6"	406	406	559	1524	1454	100	330	203	2362				
8"	540	533	650	1835	1867	100	381	216	3200				

NOTES : Inlet / Outlet flanges are according to ANSI B16.5

**DOUGLAS ITALIA S.p.A** Località Pradaglie – 29013 CARPANETO PIACENTINO ( PC )

OFFICIAL WEB SITE: [www.douglas-italia.com](http://www.douglas-italia.com)

Douglas Italia reserves the right to carry-out any necessary modification without prior notice

**DUPLEX STRAINERS**

Douglas Italia fabricated Duplex ( basket ) strainers have been specifically designed to meet all customer requirements including for high pressure applications.

Designed and fabricated to ASME VIII Div.1 as standard but can also be supplied to other pressure vessel codes. I.e. ASME B31.3 etc.

Standard features include low pressure drops at high velocities, stainless steel perforated baskets as standard, vents and drains with the possibility to supply davit lifts, quick open closures, DP gauges.

We are also able to manufacture against customer requests in all types of materials.

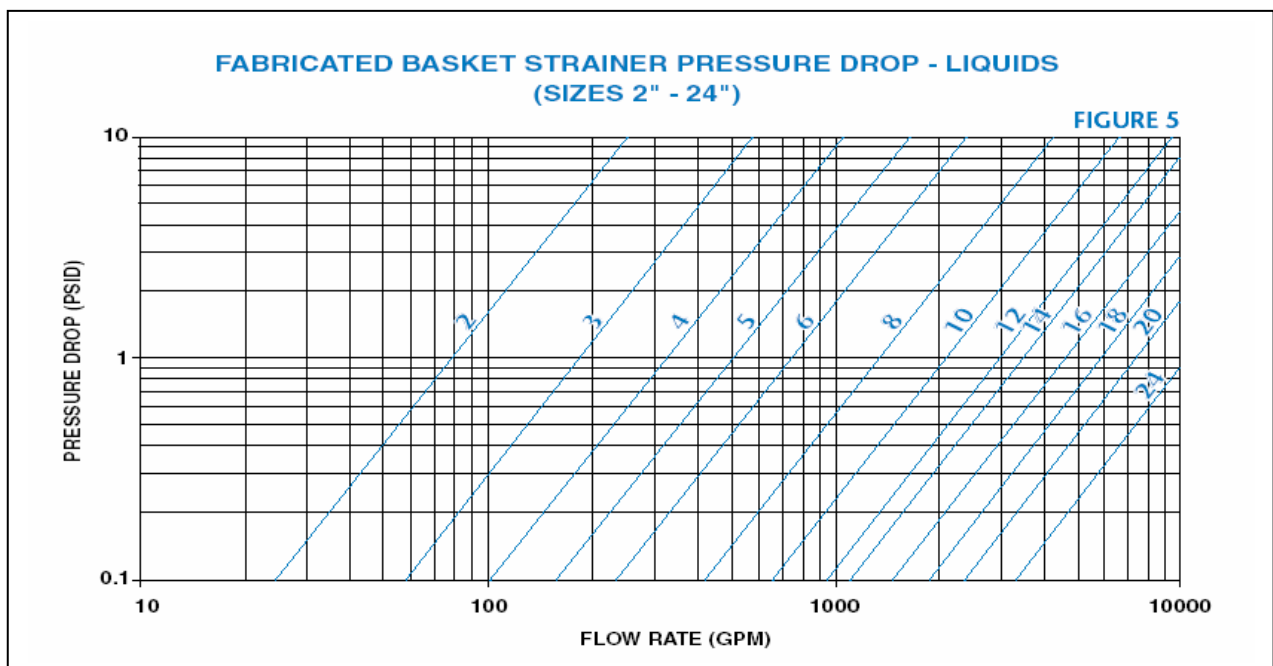

## DUPLIX FILTERS DU 300

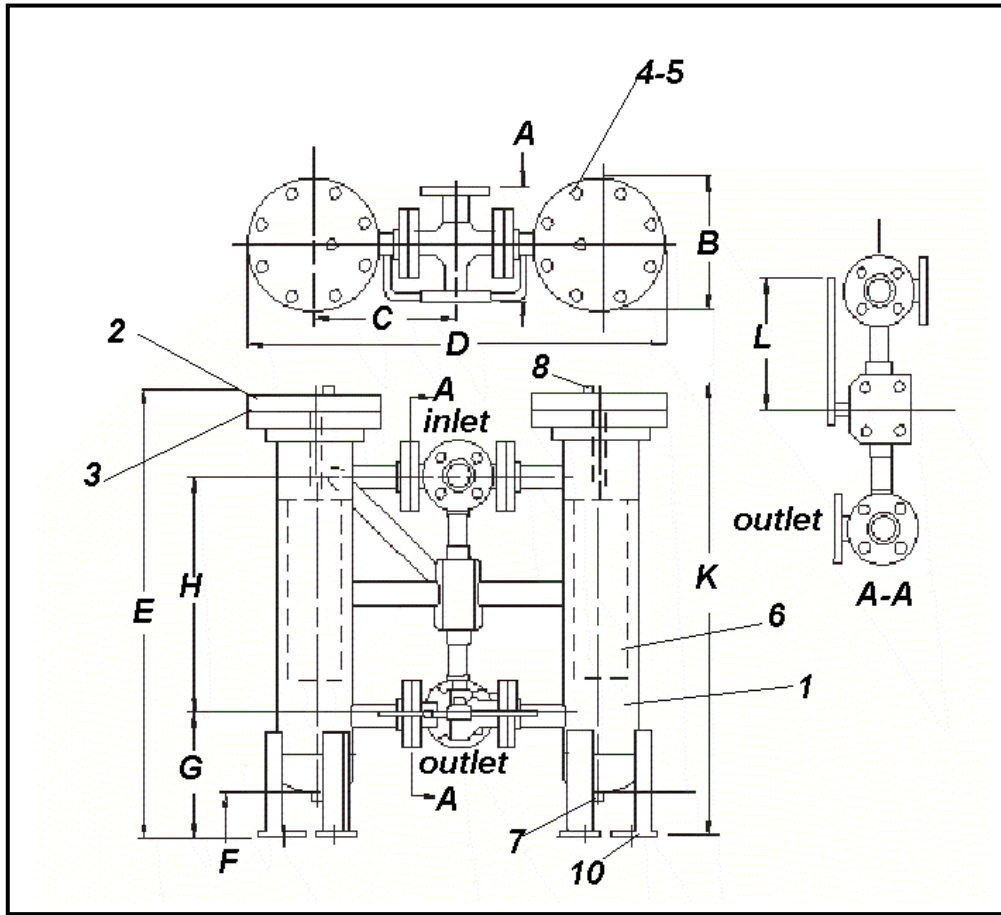

POS.	DESCRIPTION	MATERIALS	NOTE
1	Body	ASTM A106	
2	Cover	ASTM A105	
3	Gasket	316 / GRAPHITE	
4	Studs	ASTM A193 B7	
5	Nuts	ASTM A194 2H	
6	Screen	Stainless steel	
	Perf. Plate	Stainless steel	
	Mesh	Stainless steel	
7	Drain	ASTM A105	Screwed 3/4" NPT
8	Vent	ASTM A105	Screwed 3/4" NPT
9	Lifting eyes	CARBON STEEL	For cover only
10	Legs	CARBON STEEL	

Size (inches)	A	B	C	D	E	F	G	H	K				
1" - 1.1/2"	219	317	337	965	978	100	279	159	1524				
2"	240	317	346	981	1003	100	279	159	1550				
3"	290	317	372	1035	1118	100	279	159	1700				
4"	351	381	454	1286	1219	100	305	190	1900				
6"	460	444	575	1594	1473	100	330	203	2362				
8"	565	584	667	1943	1899	100	381	216	3200				

**NOTES : Inlet / Outlet flanges are according to ANSI B16.5**

**DOUGLAS ITALIA S.p.A** Località Pradaglie – 29013 CARPANETO PIACENTINO ( PC )

OFFICIAL WEB SITE: [www.douglas-italia.com](http://www.douglas-italia.com)

Douglas Italia reserves the right to carry-out any necessary modification without prior notice